

DATA SHEET

vibro-meter®

VibroSmart® VSV301 + VSB300 monitoring module

KEY FEATURES AND BENEFITS

- VibroSight® compatible hardware from the vibro-meter® product line
- 2 individually configurable dynamic input channels with up to 19 kHz bandwidth
- 1 auxiliary input channel configurable as either a tachometer or a DC input
- Synchronous sampling of input channels
- Up to 20 configurable processed outputs per module
- Spectrum analyzer (FFT) up to 1 600 lines every 100 ms
- Up to 4 alarms per processed output, with hysteresis and time delay
- AND, OR and majority voting logic functions for the combination of alarm and status information
- VibroSmart® security (module lock)
- Redundant communications and redundant power supply inputs to improve availability
- Analog outputs: 2 local outputs configurable as 4-20 mA or ± 5 V
- Discrete outputs: 2 local relays
- Real-time Ethernet communications



Information contained in this document may be subject to export control regulations of the European Union, USA or other countries. Each recipient of this document is responsible for ensuring that transfer or use of any information contained in this document complies with all relevant export control regulations. ECN N/A.



VSV301 monitoring module
(+ VSB300 terminal base)



IEC 61850-3 EMC

KEY BENEFITS AND FEATURES (continued)

- Live insertion and removal of modules (hot-swappable) with automatic reconfiguration
- Fully software configurable
- Robust enclosures with DIN rail mounting

APPLICATIONS

- Vibration and/or combustion monitoring
- Machinery protection and/or condition monitoring
- Conforms to IEC 61850-3 requirements for power plant and utility applications

DESCRIPTION

Introduction

The VibroSmart® distributed monitoring system (DMS) is a system of modular and scalable products designed for condition monitoring and machinery protection applications for power generation turbines, oil and gas applications and auxiliary balance-of-plant equipment.

VibroSmart® modules can be mounted directly on machinery, reducing the need for expensive cabling, because they are designed and certified to work in extremes, such as harsh industrial environments characterized by potentially explosive atmospheres (Ex Zone 2), high temperatures (70°C, 158°F) and high mechanical stress. VibroSmart® complements the VM600 series of rack-based solutions from Meggitt's vibro-meter® product line and is compatible with the same VibroSight® machinery monitoring system software.

The VibroSmart® VSV301 monitoring module has two independent dynamic vibration channels and one auxiliary channel, that can be configured as either a tachometer or a DC input channel. The VSV301 module is capable of stand-alone vibration monitoring or can be integrated with other VibroSmart modules to create a larger system with more measurement channels and features.

VibroSmart distributed monitoring system

A VibroSmart® distributed monitoring system (DMS) is a network of small and economical modules providing measurement, communications or other functions that are connected together in distributed, networked measurement blocks in order to provide the functionality normally offered by rack-based machinery monitoring systems. A VibroSmart system consists of one or more measurement blocks, each containing up to sixteen VibroSmart modules, a power supply and an optional host computer running the VibroSight software.

A measurement block is a logical grouping of VibroSmart modules that allows data such as tachometer, trigger and alarm information to be shared, for example, in order to monitor the same machine. Measurement blocks are configured using the VibroSight® software.

Note: A VibroSmart system is limited to a maximum of sixteen VSV30x modules per

measurement block and a maximum of eight measurement blocks without VibroSmart VSN010 real-time Ethernet switches. However, if each measurement block contains a VSN010, then a higher number of measurement blocks can be achieved, limited only by overall system performance (network traffic, VibroSight computer configuration and so on).

A VibroSmart module consists of an electronics module (providing configurable machinery monitoring functions) that clips into a VibroSmart terminal base, which mounts on a DIN rail.

VibroSmart terminal bases incorporate buses and connectors to provide all of the I/O connections required to interface to a VibroSmart module. Terminal bases also include non-volatile memory to store the configuration of the attached VibroSmart module, which allows modules to be hot-swapped. Modules and terminal bases use mechanical key-coding for a system that is simple to operate and use.

Different VibroSmart modules, terminal bases and fieldbus communications adaptors can be combined to offer unique combinations of functionality, versatility and safety assurance. In this way, a monitoring system can be built to meet the exact needs of an application resulting in a more cost-effective and reliable solution.

VSV301 monitoring module

The VSV301 monitoring module performs the data acquisition and all of the signal processing (filtering, analog-to-digital conversion, time and frequency domain processing, and resampling) required to produce processed outputs and extracted data for physical output and data presentation in VibroSight and VibroSight Scope. This includes spectral band extractions, advanced FFT analysis, trending and limit checks (alarm and sensor OK), and run-up / run-down acquisition.

In addition, the VSV301 module has four basic and two advanced logic functions that can be used to combine local alarm and status information in order to drive the module's relays. This local information and the logic function outputs can also be used as inputs to the basic logic functions of a VSI010 communications interface module in the same measurement block.

DESCRIPTION (continued)

Like all VibroSmart modules, the VSV301 module is fully software configurable using the VibroSight software. Using VibroSight Configurator, a module can be configured to capture data continuously at scheduled intervals or on the detection of an alarm condition. In addition, spectral resolution, frequency bandwidth, windowing function and averaging are all fully configurable.

Using VibroSight Vision, an extensive catalogue of plots is available for the visualisation and analysis of measurement data.

Different versions of the VSV30x module

Two different versions of VibroSmart VSV30x monitoring module are available: the VSV301 and the VSV300.

- For the VSV301, the dynamic channel buffered outputs are buffered (output-to-input ratio of 1:1) and a VSA301 buffered output amplifier is only required for signal transmission over long distances (up to 500 m).
- For the VSV300, the dynamic channel buffered outputs are attenuated (output-to-input ratio of 1:10) and require a VSA301 buffered output amplifier to make the “raw” sensor signals available at their original amplitude.

Apart from the transfer ratio (dynamic channel buffered outputs described above) and measurement phase accuracy (see **Buffered outputs – dynamic channels on page 9**), and maximum operating temperature (see **Environmental on page 11**), the VSV301 and VSV300 are the same, and both use the same VSB300 terminal base.

Communications

All VibroSmart modules and devices communicate using a system bus (SBUS), based on Ethernet technology, that supports data transfer rates of 100 Mbps at distances up to 100 m. The SBUS ensures the transfer of both non-real-time (standard) and real-time (time critical) information between VibroSmart modules, and supports communication with the host computer running the VibroSight software.

VibroSmart modules can either be located side-by-side (adjacent to each other) or separate from one another. This flexibility allows the functionality of the monitoring system to be

distributed depending on the size of and access to the machinery being monitored. It also helps reduce the expensive sensor cabling typically required between sensors and monitoring modules, by effectively replacing it with lower cost Ethernet and power supply cabling.

VibroSmart modules that are located side-by-side can communicate directly (no Ethernet cabling required) using the sidebus connectors on the terminal base that support both SBUS and redundant power supply distribution. VibroSmart modules that are mounted separate from one another can communicate over standard and redundant Ethernet networks of shielded twisted-pair Ethernet cable using the Ethernet connectors on the terminal base. However, using these Ethernet connectors does require that the power supply is distributed separately.

Discrete signal interface (DSI) inputs, including the module lock signal, and tachometer signals can be connected directly to individual modules (locally). Alternatively, to reduce external wiring, these signals can be connected to a single VibroSmart module and shared among modules in the same measurement block using the SBUS.

Security

The VSV301 + VSB300 support a module lock feature that can be used to limit the functionality of a VibroSmart® distributed monitoring system (DMS), as required. Enabling module lock, for a module, measurement block or system, helps to reduce the possibility of interference in the operation of the monitoring system itself and in the machinery being monitored.

Accordingly, VibroSmart® security (module lock) makes it easier for operators to comply with international security / critical infrastructure regulations. Refer to the *VibroSmart® distributed monitoring system (DMS) hardware manual* for further information.

Software

The VibroSight software supports the configuration and operation of VibroSmart modules, including the storage, display and/or further processing of VSV30x data for analysis. For example, measurements (dynamic or static) can be logged to a VibroSight Server data repository and/or displayed in the VibroSight Vision software.

DESCRIPTION *(continued)*

The VibroSight Vision plot catalogue includes static plots such as Bar chart, Spider, Table, Trend, Bode, Polar, Correlation and Shaft Centerline, and dynamic plots such as Waveform, Long Waveform, Polar Waveform, Orbit, Corbit, Spectrum and Full Spectrum, Waterfall/Cascade, and Full Waterfall/Cascade.

In addition, the VibroSmart Tools edition of VibroSight is a special reduced functionality (lower cost) version of the software with a simplified user interface that is intended for use with VibroSmart systems only. This edition is capable of handling live data for static measurements directly from VibroSmart system (that is, it is not possible to connect to a VibroSight Server).

Refer to the *VibroSight® machinery monitoring system software data sheet* for further information.

Applications information

The VSV301 monitoring module is ideal for monitoring, protecting, analysing and diagnosing critical assets such as gas turbines, steam turbines, hydro turbines and other rotating machines. A VSV301 can be used as a stand-alone module or as part of a more comprehensive monitoring system operating with a VibroSight Server (and data repository).

VibroSmart® systems (VSV30x + VSB300, VSI010 + VSB010 and VSN010) conform to the IEC 61850-3 requirements for power plant and utility applications – when installed in specific configurations. Contact Meggitt SA and/or refer to the *VibroSmart® distributed monitoring system (DMS) hardware manual* for further information.

For specific applications and other information, contact your local Meggitt representative.

SPECIFICATIONS

Supported sensors

Currently available : Compatible with a range of sensors and signal conditioners using 2-wire current transmission and 3-wire voltage transmission

Dynamic input channels

Number of independent channels : 2

Measurement range

- Voltage (AC+DC) : ± 3 or $\pm 30 V_{PEAK}$
- Current : 15 or 150 mA

Frequency bandwidth (–0.1 dB) : 0.1 Hz to 19 kHz

- Analog high-pass filter : An optional (software configurable) analog high-pass filter can be added to the AC path to configure the high-pass cutoff frequency (–3 dB) as 0.1, 1.0 or 3.0 Hz. This filter can also be disabled to allow DC-coupling of the input.

Input impedance

- Voltage : $\geq 100 \text{ k}\Omega$, between the differential (high and low) inputs
- Current : $202 \Omega \pm 3 \Omega$, between the differential (high and low) inputs

Accuracy

- Amplitude : $\leq 1\%$ of input FSD (measurement bandwidth from 10 Hz to 1 kHz)
- Phase : $\leq 1.5^\circ$ (measurement bandwidth from 10 Hz to 1 kHz)

Signal to noise ratio (SNR) : $\geq 80 \text{ dB}$ (measurement bandwidth from 10 Hz to 2 kHz)

Common-mode voltage (CMV) range : $\pm 5 \text{ V}$

Common-mode rejection ratio (CMRR) : $> 60 \text{ dB}$ (at 50/60 Hz)

Crosstalk attenuation : Typically 60 dB

Auxiliary input channel – used as a tachometer input

Triggering method : Crossing of threshold on rising edge of signal

Triggering threshold (rising edge) : 2/3 of peak-peak value

Voltage range : $\pm 30 V_{RMS}$ / $\pm 42.4 V_{AC (PEAK)}$ or $60 V_{DC}$

⚠ For Ex Zone 2 applications, the voltage range of the auxiliary input channel of a VSV301 + VSB300 monitoring module and terminal base must be limited to $\leq 60 V_{PK-PK}$.

Tacho range : 0.017 Hz to 426 kHz
(on input)

Speed/frequency measurement range : 1 to 100000 RPM / 0.017 Hz to 1.667 kHz
(after division by “number of teeth”)

Minimum input voltage for reliable detection

- Square-wave input signal : $0.8 V_{PK-PK}$ (0.017 Hz to 10 kHz)
 $2.0 V_{PK-PK}$ (10 kHz to 427 kHz)
- Sinusoidal input signal : $20.0 V_{PK-PK}$ (0.017 Hz to 0.1 Hz)
 $10.0 V_{PK-PK}$ (0.1 Hz to 1.0 Hz)
 $2.0 V_{PK-PK}$ (1.0 Hz to 20.0 Hz)
 $0.8 V_{PK-PK}$ (20.0 Hz to 10.0 kHz)
 $2.0 V_{PK-PK}$ (10.0 kHz to 426.4 kHz)

Input impedance

- Voltage : $\geq 110 \text{ k}\Omega$, between the differential (high and low) inputs
- Current : $202 \Omega \pm 3 \Omega$, between the differential (high and low) inputs

SPECIFICATIONS *(continued)*

Auxiliary input channel – used as a DC input

Measurement range

- Voltage (DC) : ± 20 V
 - Current : ± 100 mA
- Frequency bandwidth (-3 dB) : DC to 10 Hz

Input impedance

- Voltage : ≥ 110 k Ω , between the differential (high and low) inputs
- Current : $202 \Omega \pm 3 \Omega$, between the differential (high and low) inputs

Signal to noise ration (SNR) : ≥ 72 dB

Sensor OK check

Range : -20 to +20 V_{DC}

Operating principle

- Powered sensors : DC voltage monitoring (open-circuit and short-circuit line check)
- Unpowered sensors : Open-circuit line check only

Digital signal processing

A/D converter : 24 bit

Dynamic range : ≥ 80 dB (from 10 Hz to 2 kHz)

Frequency bandwidth : 0 Hz to 19 kHz

Accuracy

- Amplitude : $\leq 1\%$ of input FSD
- Phase : $\leq 1.5^\circ$ (measurement bandwidth from 10 Hz to 1 kHz)

Digital filtering

- High-pass filter cutoff frequency : 0.25 Hz to 10 kHz (main path)
- High-pass filter roll-off : -20 to -60 dB per octave
- Low-pass filter cutoff frequency : 10 Hz to 19 kHz (main path)
- Low-pass filter roll-off : -20 to -60 dB per octave

Measurement resolution : 256 to 4096 point waveform / 100 to 1 600 line spectrum

FFT window : Flat top; Hamming; Hann (Hanning); Kaiser-Bessel with an alpha of 1, 5, 10, 20 or 25; Rectangular

Averaging (frequency domain) : Exponential averaging with up to 100 averages

Extracted data : Up to 20 processed outputs per module

Extracted data type : Scalar, Vector, Phasor, Frequency line

Integration count : 0, 1 or 2

Qualifiers (rectifiers) : True RMS, Scaled peak, Scaled peak-peak, Scaled average, True average, True peak, True peak-peak and Band peak

Order tracking : Digital resampling

VibroSight[®] software update rate (external) : Standard (default) VSV30x module update rate of 1 s. Configurable as 100 ms, 200 ms, 500 ms, 1 s, 2 s, 5 s, 10 s, 20 s, 30 s or 1 min on a per module basis.

VibroSight[®] data logging : Data (and event) logging to a VibroSight database at rates from 100 ms, as per the data logging rules configured for an application. Note: Pre-logging and/or post-logging to log information at a higher data logging rate for specific time durations leading up and/or following alarm events. The pre-logging duration is fixed at 60 s max.

SPECIFICATIONS *(continued)*

Single-channel processing blocks

VSV30x modules support flexible input channel to processing block mapping with a 1:n relationship between input channels and processing blocks that allows different processing blocks of a module to use the same input channel. The number of processed outputs (data extractions) available depends on the processing block.

Asynchronous absolute bearing vibration (AAB)

- Main path with band-pass filter : Up to 3 outputs: one after the band-pass filter, one after the first integrator and one after the second integrator.
Note: ISO 2954 compatible values can automatically be configured for the band-pass filter, if required.
- Secondary path with low-pass filter : Spectrum (configurable averaging and integration) and up to 5 outputs. Waveform and up to 3 outputs.

Shaft relative vibration (RS)

- Main path with separate AC and DC paths : AC path with band-pass filter and up to 4 outputs.
DC path with 1 output corresponding to the actual position of the shaft or target.
- Secondary path : Spectrum (configurable averaging) and up to 8 outputs.
Waveform.

Narrow-band vibration (NB)

- With averaging and narrow band-pass filter : Spectrum (configurable averaging and integration) and up to 11 outputs.
Waveform.
Note: Narrow-band vibration (NB) is an order-tracked measurement and requires a tachometer input (1/rev) in order to track rotational speed. Each Narrow-band vibration (NB) processing block requires its own dedicated tacho processing block.

Broad-band pulsation (BBP)

- Main path with band-pass filter and notch filter : Up to 2 outputs.
Note: The notch filter can be configured as either 50 or 60 Hz to eliminate mains (power-line) frequency interference.
- Secondary path with low-pass filter : Spectrum (configurable band rejection and averaging) and up to 5 outputs. Waveform and up to 3 outputs.

Position (PS)

- DC path with offset (initial gap) : DC path with 1 output corresponding to the actual position of the shaft or target.
Notes: Position (PS) and shaft relative vibration (RS) processing blocks use the same signal processing functions to generate a position output. Position (PS) processing can be used with an auxiliary input channel configured as a DC input channel and with the dynamic Input channels.

Tacho

- With configurable “number of teeth” and “tacho ratio” : 1 output corresponding to the rotation speed of the shaft or target.
Note: The tachometer input can be either the tachometer input of the module (local) or the tachometer input of a module in the same measurement block as the module (remote).
Note: Even though there is one tachometer (auxiliary) input per VSV30x module, two tacho processing blocks can be configured in order to allow signals from related shafts to be easily monitored and compared using Narrow-band vibration (NB) processing.

SPECIFICATIONS *(continued)*

Dual-channel processing blocks

Dual shaft relative

- Orbit : 1 output corresponding to an “overall” (unfiltered) orbit. An orbit is obtained directly from shaft relative vibration (RS) processing block waveforms.
- Filtered orbit : 1 output corresponding to a multiple of the rotation speed of the shaft, such as 0.5X, 1X, 2X and so on. A filtered orbit is obtained from shaft relative vibration (RS) processing block vectors (frequency-domain extractions).
- S_{max} : 1 output corresponding to S_{max} calculated using either ISO 7919-1 method C or ISO 7919-1 method B.
 - ISO 7919-1 method C:

$$S_{max (PEAK)} = \text{Maximum} \{ \sqrt{X(t)^2 + Y(t)^2} \}$$
 - ISO 7919-1 method B:
 X-Ymax discriminator = $S_{max(PK-PK)} = \text{Maximum} \{ X^2_{(PK-PK)}, Y^2_{(PK-PK)} \}$

In addition, an S_{max} output is available as either true peak (t_{pk}) or scaled true peak-peak (st_{pp}) using a configurable qualifier (rectifier) and averaging.

Alarm processing

Alarms

- : Four configurable alarm ranges (Danger+, Alert+, Alert-, Danger-) with configurable hysteresis and time delay

Adaptive monitoring

- : Adaptive monitoring uses a control parameter (such as speed or position) to multiply the configured alarm limits by multiple coefficients configured for different ranges of the control parameter.
Trip multiplier uses the DSI TM control signal to multiply the configured alarm limits by a single configurable coefficient.

Alarm combination

Logic functions

- : AND, OR and majority voting logic, with optional inversion of individual inputs

Basic logic functions

- Number : 4
- Configurable inputs : From the sensor OK checks, and the measurement alarms (Danger+, Alert+, Alert-, Danger-) and associated data quality indicators (status bits) of the module

Advanced logic functions

- Number : 2
- Configurable inputs : From the basic logic function outputs of the module

Discrete signal interface (DSI) inputs

Control signal

- Alarm bypass (AB) : A closed contact between the DSI AB and RET inputs inhibits the local relay outputs for the entire module
- Alarm reset (AR) : A closed contact between the DSI AR and RET inputs resets the alarms/relays latched by the module

SPECIFICATIONS *(continued)*

• Trip multiply (TM)	: A closed contact between the DSI TM and RET inputs multiplies the alarm levels by a scale factor (software configurable), to enable trip multiplier-based adaptive monitoring
• Module lock (Lock)	: A closed contact between the DSI Lock and RET inputs effectively locks the module, for security and/or operational reasons. Note: A locked module prevents configuration changes (operational configuration, firmware updates, time synchronisation and network settings) and restricts operations (no alarm bypass (AB), Trip multiply (TM) or channel bypass from VibroSight Scope).
Operating principle	: Detection of an open circuit or a closed circuit on the input. These control signals can be connected directly to individual modules (locally) or connected to a single module (the DSI Master) and shared among modules in the same measurement block using the SBUS (remotely).

Discrete signal interface (DSI) commands

VibroSight Scope command

• Alarm bypass (AB)	: Software command to control module functionality as per equivalent DSI control input signal
• Alarm reset (AR)	: Software command to control module functionality as per equivalent DSI control input signal
• Trip multiply (TM)	: Software command to control module functionality as per equivalent DSI control input signal
• Channel 1 bypass, Channel 2 bypass, Aux channel bypass	: Software commands to inhibit the local relay outputs for a particular channel of a module. Note: This functionality is intended for temporary use in order to support machinery maintenance activities.
Operating principle	: In the VibroSight Scope software, DSI commands (controls) are used to enable/disable DSI functionality for the connected module

Buffered outputs – dynamic channels

Type	: Buffered transducer “raw” analog output
Number	: 2, available on J2 of the terminal base (see Connectors on page 15)
Frequency bandwidth	: 0 Hz to 19 kHz
Accuracy	
• Amplitude	: ≤1% (measurement bandwidth from 0 Hz to 19 kHz)
• Phase	: ≤1° (measurement bandwidth from 10 Hz to 2 kHz). ≤10° (measurement bandwidth from 2 kHz to 19 kHz).
Transfer ratios	
• Voltage input	: 1 V/V (output-to-input ratio of 1:1, non-inverting)
• Current input	: 202 mV/mA (non-inverting)
Admissible load on output	
• Resistance	: ≥50 kΩ
• Capacitance	: Able to drive up to 3 m of cable with a typical capacitance of 100 pF/m

Note: Where required, a VSA301 buffered output amplifier can be used to transmit a VSV301 module's dynamic channel buffered outputs over distances up to 500 m.

SPECIFICATIONS *(continued)*

Buffered output – auxiliary channel

Type	: Buffered transducer “raw” digital output. When the auxiliary channel is configured as a tachometer input, the buffered transducer “raw” output for the auxiliary channel is a processed tachometer output. This buffered output is generated only when the tachometer is connected directly (locally) to the module. Note: When the auxiliary channel is configured as a DC input, there is no buffered output.
Number	: 1, available on J2 of the terminal base (see Connectors on page 15)
Voltage transfer ratio	: 0 to 5 V TTL-compatible signal (non-inverting)
Admissible load on output	
• Resistance	: $\geq 50 \text{ k}\Omega$
• Capacitance	: Able to drive up to 5 m of cable with a typical capacitance of 100 pF

Note: Where required, a VSA301 buffered output amplifier can be used to transmit a VSV301 module's auxiliary channel buffered output (processed tachometer output) over distances up to 500 m.

Analog outputs

Number of local outputs	: 2 single-ended
Configurable as either	
• 4-20 mA (DC)	: Used to output a static signal (extracted data)
• $\pm 5 \text{ V}_{\text{PEAK}}$ (AC)	: Used to output processed versions of a single dynamic channel signal
Admissible load on output (DC)	: $\leq 360 \Omega$
Admissible load on output (AC)	: $\geq 50 \text{ k}\Omega$
Frequency bandwidth (AC)	: 0 Hz to 10 kHz
Amplitude accuracy (AC)	: 1% typ. (measurement bandwidth from 10 Hz to 2 kHz)

Discrete outputs

Local relays	
• Number	: 2
• Configurable functions	: Normally energized (NE) or normally de-energized (NDE). Latched or unlatched.
• Configurable inputs	: From the sensor OK checks, the measurement alarms (Danger+, Alert+, Alert-, Danger-) and the logic function outputs of the module

@@Relay characteristics

Number	: 2 × user-configurable relays (RL1 and RL2).
Type	: Double-pole double-throw (DPDT) / 2 Form C
Contact arrangement	: 1 × COM, 1 × NC and 1 × NO contact per relay (RL1 and RL2) available on J3 of the terminal base. See Connectors on page 15 .
Nominal switching capacity (resistive load)	: 0.5 A 125 V _{AC} / 1 A 30 V _{DC}
Maximum switching power (resistive load)	: 62.5 VA / 30 W

SPECIFICATIONS *(continued)*

Maximum switching voltage : 125 V_{AC} / 110 V_{DC}
 Maximum switching current : 1 A
 Maximum switching capacity curves :

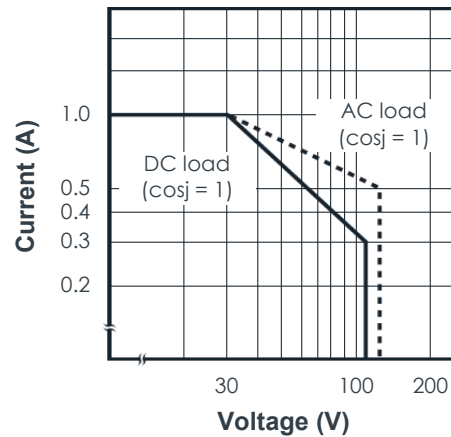

Operate / release time : 3 ms (max.) / 3 ms (max.)
 Breakdown voltage : >500 V
 Insulation resistance : 1000 MΩ min. (at 500 V_{DC})
 Mechanical life : >10⁸ operations (min.)
 Electrical life : >10⁵ operations (min.)

Note: In general, VSV301 + VSB300 module relays are limited to 63 V_{AC} max. in accordance with the EN 61010 electrical safety standard. For applications, the relays withstand 125 V_{AC} and VibroSmart modules are routinely tested with a dielectric voltage of 500 V_{AC}.

⚠ For Ex Zone 2 applications, the voltage and current switched by a VSV301 + VSB300 relay must be limited in accordance with Table A.1 of EN/IEC 60079-11, with a maximum voltage of 45 V or a maximum current of 2 A.

Environmental

Operating

- Temperature : -20 to 70°C (-4 to 158°F)
- Humidity : 0 to 90% non-condensing

Storage

- Temperature : -40 to 85°C (-40 to 185°F)
- Humidity : 0 to 95% non-condensing

Protection rating : IP20.
 (according to IEC 60529) It is also possible to deploy VibroSmart modules and devices within an industrial housing in order to attain a protection rating of IP56. Contact Meggitt for further information.

⚠ For Ex Zone 2 applications, a VSV301 + VSB300 monitoring module and terminal base must be installed in an industrial housing or enclosure that ensures a protection rating of at least IP54 (or equivalent).

SPECIFICATIONS *(continued)*

Potentially explosive atmospheres

Ex approved for use in hazardous areas

Type of protection Ex ic: intrinsic safety, Ex nA: non-sparking		
Europe	EC type examination certificate	Ex II 3 G (Zone 2) Ex nA IIC T6...T4 Gc LCIE 13 ATEX 1041 X
International	IECEX certificate of conformity	Ex nA IIC T6...T4 Gc IECEX LCIE 13.0058X
North America	cCSAus certificate of compliance	Class I, Division 2, Groups A, B, C, D T6...T4 Ex ic nA IIC T6...T4 Gc Class I, Zone 2 AEx ic nA IIC T6...T4 Gc cCSAus 70010491
United Kingdom	Type examination certificate*	Ex II 3 G Ex nA IIC T6...T4 Gc CML 21 UKEX 4547 X
Russian Federation	EAЭC RU certificate of conformity	2Ex nA IIC T6...T4 Gc X EAЭC RU C-CH.AΔ07.B.04690/22

*Not engraved/marked on the product.

 **For specific parameters of the mode of protection concerned and special conditions for safe use, refer to the Ex certificates that are available from Meggitt SA.**

 **When using protection mode “Ex nA” (non-sparking), the user must ensure that the VSV301 + VSB300 are installed in an industrial housing or enclosure that ensures a protection rating of at least IP54 (or equivalent).**

 **For the most recent information on the Ex certifications that are applicable to this product, refer to the Ex product register (PL-1511) document that is available from Meggitt SA.**

Approvals

Conformity	: European Union (EU) declaration of conformity (CE marking). United Kingdom (UKCA) declaration of conformity. EAC marking, Eurasian Customs Union (EACU) certificate/ declaration of conformity.
Electromagnetic compatibility (EMC)	: EN 61000-6-2:2005. EN 61000-6-4:2007 + A1:2011. EN 61326-1:2006. TR CU 020/2011. IEC 61850-3 (Note: Specific VibroSmart configurations only).
Electrical safety	: EN 61010-1:2010. TR CU 004/2011.
Environmental management	: RoHS compliant (2011/65/EU)
Hazardous areas	: Ex (see Potentially explosive atmospheres on page 12)
Russian federal agency for technical regulation and metrology (Rosstandart)	: Pattern approval certificate OC.C.28.004.A N° 60224

SPECIFICATIONS *(continued)*

SBUS communications

Type	: Real-time Ethernet
Network interface	: 100BASE-TX
Data transfer rate	: Up to 100 Mbps
Distance between devices	: Up to 100 m at 100 Mbps (100BASE-T compliant)
Network topologies	: Linear and HSR ring
Number of modules	: Up to 128 × modules per VibroSmart system (without using VSN010 real-time Ethernet switches): <ul style="list-style-type: none">• Up to 16 × modules per measurement block (16 × VSV30x modules max.)• Up to 8 × measurement blocks per VibroSmart system.
Signals shared across a measurement block	
• Real-time	: Tachometric time-stamp, trigger and alarm messages
• Non-real-time	: Remote DSI inputs. Measurement data (processed outputs and extracted data).

Note: SBUS is the system bus, based on real-time Ethernet, used by a VibroSmart system for all communications. The SBUS supports inter-module communication between VibroSmart modules such as the transfer of non-real-time information and real-time information such as tachometric time-stamps, triggers and alarms. It also supports extra-module communications such as the exchange of commands, configuration information and measurement data between VibroSmart modules and a host computer running the VibroSight software. The SBUS is also used for communication with external NTP and/or PTP network time server(s), if used.

Configuration

VibroSmart modules	: Fully software configurable over Ethernet, using a host computer running the VibroSight software
Terminal bases	: A DIP switch on the terminal base selects either the sidebus connector (J1x) or the Ethernet connector (Ethx) as the active SBUS port for each side of the terminal base. Only two physical ports can be active at any one time, that is, either J11 or Eth1 (right side) and either J10 or Eth2 (left side).

Time synchronisation

Local synchronisation between VibroSmart modules (inter-module synchronisation)	
• Protocol	: Precision time protocol (PTP)
• Accuracy	: <1 μs. Note: Module to module measurement time synchronisation between different VibroSmart modules in the same measurement block.
• Required	: Yes (mandatory). For each VibroSmart measurement block, one module automatically acts as the PTP server (slave) for the other (client) modules in the measurement block.

SPECIFICATIONS *(continued)*

Global synchronisation between VibroSmart systems and other systems (extra-module synchronisation)

- Protocols : Network time protocol (NTP)
- Accuracy : <10 ms typ. with an external NTP server.
Note: Module to module measurement time synchronisation between different VibroSmart modules (VSV30x and VSI010) in the same VibroSmart system.
- Required : No (optional).
For a VibroSmart system, an NTP server can be manually configured as a common time reference in order to synchronise VibroSmart modules and/or third-party systems.

Local/global synchronisation between VibroSmart modules, VibroSmart systems and other systems (using a VSN010 switch as a PTP bridge)

- Protocols : Precision time protocol (PTP)
- Accuracy : <1 ms (<0.5 ms typ.) with an external PTP server.
Note: Module to module measurement time synchronisation between different VibroSmart modules (VSV30x only) and VibroSmart systems.
- Required : No (optional).
For a VibroSmart system, a VSN010 switch can be used as a PTP bridge device (that is, configured to use a PTP server) in order to synchronise VibroSmart modules, VibroSmart systems and/or third-party systems.

Power supply (input)

- Voltage : 24 V_{DC} nominal (+16 to +32 V_{DC} input range)
- Redundancy : Two separate inputs for connection to different external power supplies

Power supplies to sensors (outputs)

- Number of independent sensor power supplies : 3 (one per input channel)
- Sensor power supply output
 - Constant voltage : +24V_{DC} ±3% (+25mA max.) or -24V_{DC} ±3% (-25mA max.)
 - Constant current : +6 mA ±1%

Power consumption

- Total power consumption : <8 W, with sensor power supplies enabled

LED indicators

- Status
 - : Diag – indicates the status of the module, such as normal operation, configuration status or internal hardware or firmware failures.
 - : Network – indicates Ethernet link activity and status, and network time server synchronisation.
 - : Safety – indicates the status of the module's safety function and any active adaptive monitoring functions (AB or TM).
- CH 1, CH 2 and AUX
 - : OK – indicates the status (sensor OK check) of the input signal for each channel.
 - : Alarm – indicates the status of each channel, such as normal operation and alarms (Danger+, Alert+, Alert-, Danger-).

SPECIFICATIONS *(continued)*

Connectors

J1 to J6	: 10-pin terminal strip headers (male). Compatible with 10-pin BCF plug-in connectors (female) with PUSH IN spring connections having a clamping range from 0.14 to 1.5 mm ² (26 to 16 AWG) and a recommended stripping length of 9 mm. See Recommendations for reliable connections on page 20 .
<ul style="list-style-type: none">• J1, bottom rear• J2, bottom centre• J3, bottom front• J4, top front• J5, top centre• J6, top rear	: Redundant power supply inputs and local DSI inputs : Buffered version of raw input signals and analogue outputs configured for a processed output or extracted data : Local relay contacts (COM, NC and NO) : Auxiliary input channel. Note: A VibroSmart plug-in signal conditioner or other external signal conditioner may be required. : Dynamic input channel 2. Note: A VibroSmart plug-in signal conditioner or other external signal conditioner may be required. : Dynamic input channel 1. Note: A VibroSmart plug-in signal conditioner or other external signal conditioner may be required.
J10, right side J11, left side	: Proprietary connectors. Sidebus connectors for SBUS communications (extra-module and inter-module) to a VibroSmart network and for the distribution of power to modules (redundant physical paths).
Eth1, bottom right Eth2, bottom left	: 8P8C (RJ45) connectors, female. Ethernet connectors for SBUS communications (extra-module and inter-module) to a VibroSmart network. The Ethernet connectors (Ethx) are IEEE 802.3 Ethernet compatible with an isolation voltage of 1500 V _{RMS} .

Physical

Module mounting	: The VSV301 module clips into the VSB300 terminal base, which mounts on a TH 35 DIN rail (according to EN 50022 / IEC 60715). For example, TH 35-7.5 or TH 35-15.
Connection to other modules	: Sidebus connectors J10 and J11 allow direct connections between modules that are located side-by-side. Ethernet connectors Eth1 and Eth2 allow connections between modules mounted further apart, using twisted-pair Ethernet cable.
Connection to a host computer	: Ethernet connectors Eth1 and Eth2 allow connections to a host computer or network, using twisted-pair Ethernet cable
Ethernet cabling	
<ul style="list-style-type: none">• Cable lengths (network segments) less than 50 m• Cable lengths (network segments) up to 100 m	: Category 5 enhanced (Cat 5e) cable of type SF/UTP. A SF/UTP cable has overall (outer) screening using braided or foil shielding. : Augmented category 6 (Cat 6a) or augmented category 7 (Cat 7a) cable of type S/FTP. A S/FTP cable has overall (outer) screening using braided shielding and individual pair shielding using foil.

SPECIFICATIONS *(continued)*

Connection to a sensor (front-end)	: Connector J4 is dedicated to the auxiliary input channel, while connectors J5 and J6 are dedicated to the dynamic input channels. See Supported sensors on page 5 .
Connection to a power supply	: VibroSmart modules that are located side-by-side can distribute the power supply via the sidebus connectors J10 and J11 when at least one module is connected to the external +24 V _{DC} supply. VibroSmart modules that are mounted separate from one another require that each module is connected to the external +24 V _{DC} supply via its J1 connector.
Dimensions	
• VSV301 module	: See Mechanical drawings on page 17
• VSB300 terminal base	: See Mechanical drawings on page 17
Weight	
• VSV301 module	: 300 g (0.66 lb) approx.
• VSB300 terminal base	: 550 g (1.21 lb) approx.

MECHANICAL DRAWINGS

VSV301 module – front view

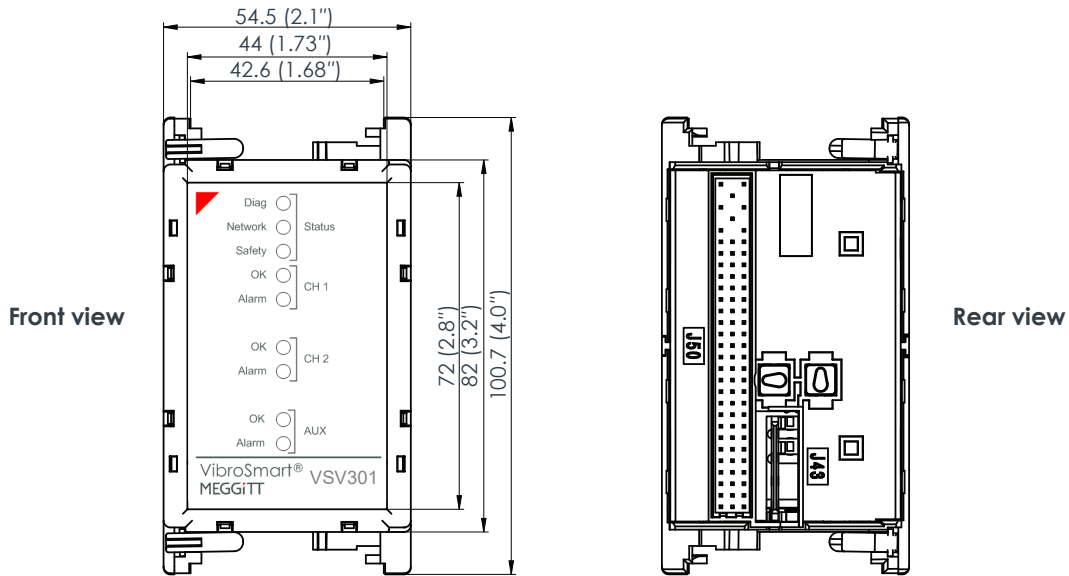

Note: All dimensions in mm (in) unless otherwise stated.

VSV301 module – other views

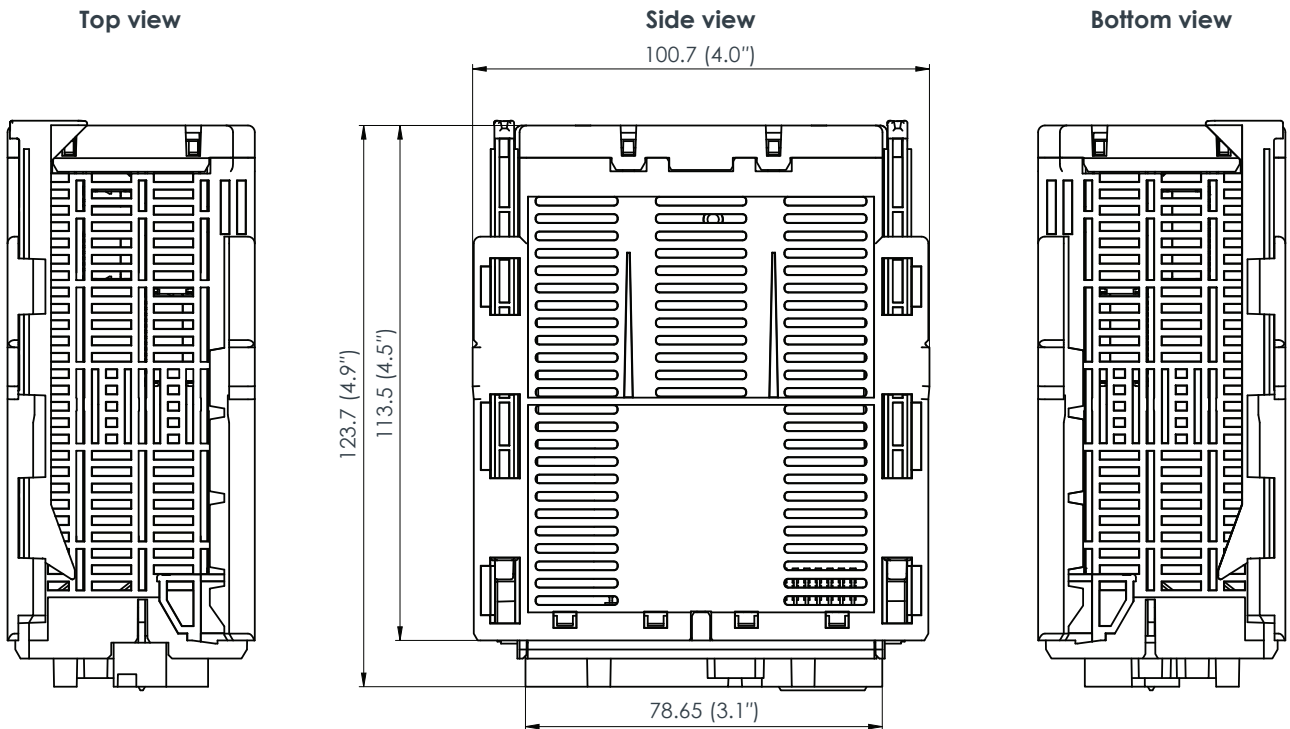

Note: All dimensions in mm (in) unless otherwise stated.

MECHANICAL DRAWINGS (continued)

VSB300 terminal base – front and rear views

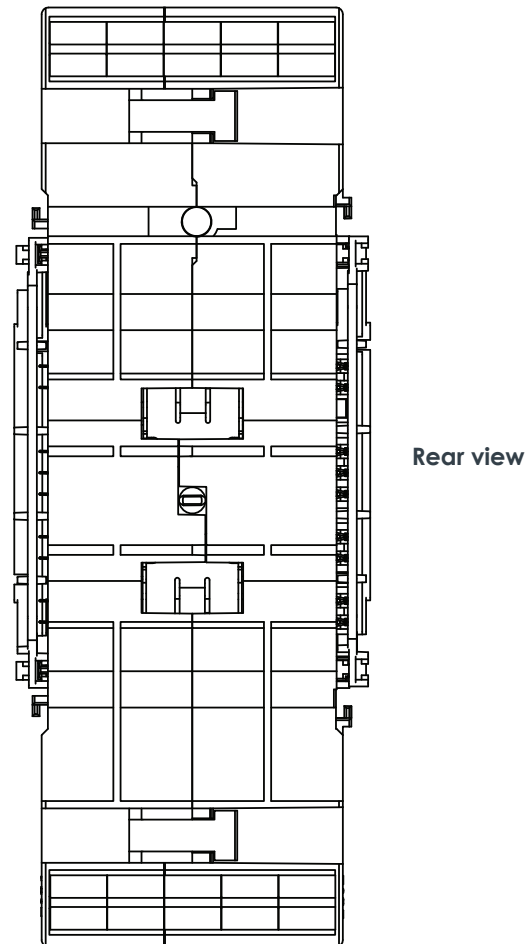
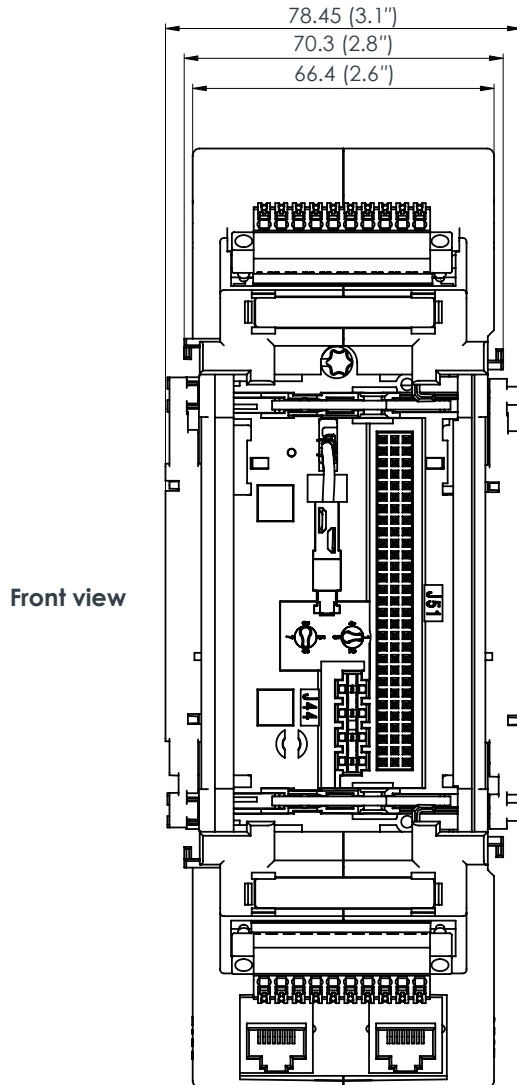

Note: All dimensions in mm (in) unless otherwise stated.

MECHANICAL DRAWINGS (continued)

VSB300 terminal base – side view

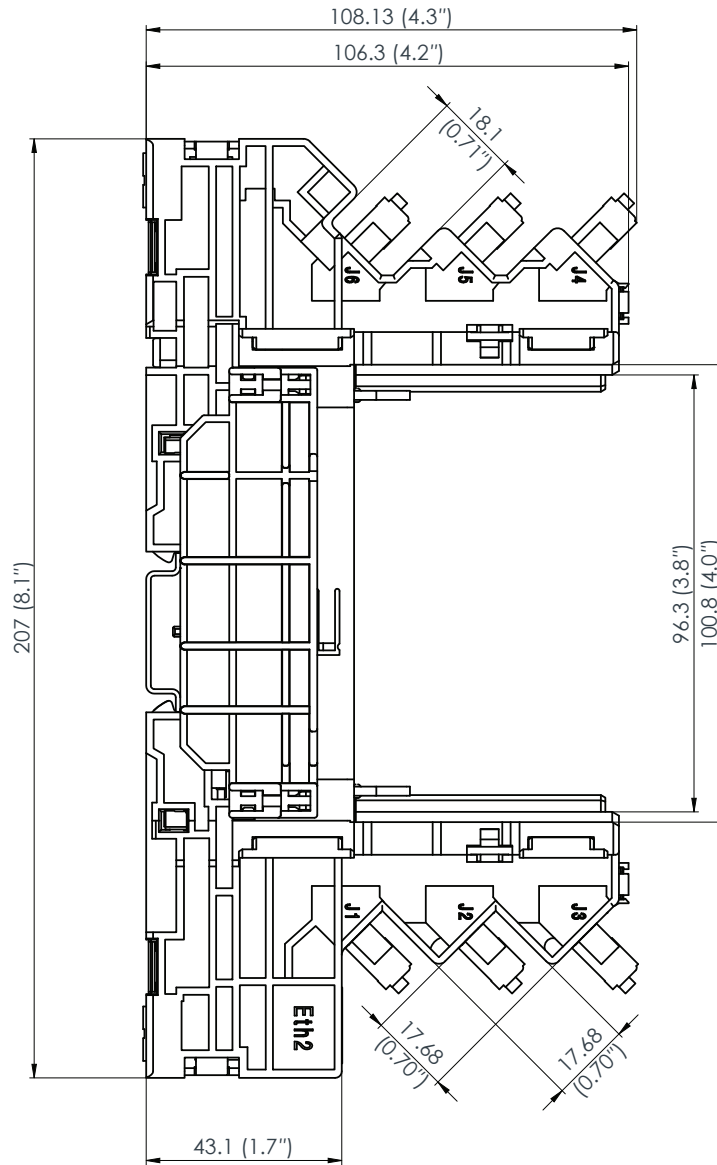

Note: All dimensions in mm (in) unless otherwise stated.

ORDERING INFORMATION

To order please specify

Type	Designation	Part number (PNR)
VSV301	VibroSmart monitoring module	600-034
VSB300	Terminal base for a VSV30x module	600-009

Notes

The VSV301 and VSV300 are the same apart from transfer ratio and measurement phase accuracy (see **Buffered outputs – dynamic channels on page 9**), and max. operating temperature (see **Environmental on page 11**), so both use the same VSB300 terminal base.

The VSV301 is supplied with a set of 6 × terminal base BCF plug-in connectors for J1 to J6 that are labelled and mechanically key-coded for the VSV301 + VSB300. Sets of additional connectors can be ordered as VSK002 (see **Accessories on page 20**).

ACCESSORIES

To order please specify

Type	Designation	Part number (PNR)
VSA001	T30 Torx driver with a length of 150 mm (suitable for the DIN rail adaptor in VSBxxx terminal bases)	975.51.54.0030
VSA002	Cable assembly for use with the buffered outputs (J2) of a VSV30x + VSB300, terminated with male BNC connectors for use as flying leads	934-129-000-011
VSA003	Cable assembly for use with the buffered outputs (J2) of a VSV30x + VSB300, terminated with female BNC connectors for use with a patch panel	934-128-000-011
VSK002	Set of 6 × terminal base BCF plug-in connectors for J1 to J6 (labelled and mechanically key-coded for a VSV30x + VSB300)	622-007-200-001

Notes

The VSA002 is a 2 m cable assembly with a terminal base connector at one end for connection to the VSB300 terminal base (J2) and three male BNC connectors at the other end (one per output signal) for direct connections to test equipment.

The VSA003 is a 2 m cable assembly with a terminal base connector at one end for connection to the VSB300 terminal base (J2) and three female BNC connectors at the other end (one per output signal) for connections to BNC patch panels.

RECOMMENDATIONS FOR RELIABLE CONNECTIONS

It is highly recommended to terminate all wires connected to the BCF plug-in connectors (female) used by J1 to J6 of the VSB300 terminal base by crimping them with the appropriate industry standard wire-end ferrules, in order to help ensure consistent and reliable connections.

RELATED PRODUCTS

APF19x	24 V _{DC} power supplies	: Refer to corresponding data sheets
APF20x	24 V _{DC} power supplies with Ex approval	: Refer to corresponding data sheets
VSA00x	VibroSmart [®] BNC cable assemblies and patch panels	: Refer to corresponding data sheet
VSI010 + VSB010	VibroSmart [®] communications interface module	: Refer to corresponding data sheet
VSN010	VibroSmart [®] real-time Ethernet switch	: Refer to corresponding data sheet
VibroSight	VibroSight [®] machinery monitoring system software	: Refer to corresponding data sheet

Meggitt (Meggitt PLC) is a leading international engineering company, headquartered in England, that designs and delivers high-performance components and subsystems for aerospace, defence and selected energy markets. Meggitt comprises four customer-aligned divisions: Airframe Systems, Engine Systems, Energy & Equipment and Services & Support.

The Energy & Equipment division includes the Energy Sensing and Controls product group that specialises in sensing and monitoring solutions for a broad range of energy infrastructure, and control valves for industrial gas turbines, primarily for the Power Generation, Oil & Gas and Services markets. Energy & Equipment is headquartered in Switzerland (Meggitt SA) and incorporates the vibro-meter[®] product line, which has over 65 years of sensor and systems expertise and is trusted by original equipment manufacturers (OEMs) globally.



All information in this document, such as descriptions, specifications, drawings, recommendations and other statements, is believed to be reliable and is stated in good faith as being approximately correct, but is not binding on Meggitt (Meggitt SA) unless expressly agreed in writing. Before acquiring and/or using this product, you must evaluate it and determine if it is suitable for your intended application. You should also check our website at www.meggittsensing.com/energy for any updates to data sheets, certificates, product drawings, user manuals, service bulletins and/or other instructions affecting the product.

Unless otherwise expressly agreed in writing with Meggitt SA, you assume all risks and liability associated with use of the product. Any recommendations and advice given without charge, whilst given in good faith, are not binding on Meggitt SA. Meggitt (Meggitt SA) takes no responsibility for any statements related to the product which are not contained in a current Meggitt SA publication, nor for any statements contained in extracts, summaries, translations or any other documents not authored and produced by Meggitt SA.

The certifications and warranties applicable to the products supplied by Meggitt SA are valid only for new products purchased directly from Meggitt SA or from an authorised distributor of Meggitt SA.

In this publication, a dot (.) is used as the decimal separator and thousands are separated by thin spaces. Example: 12345.67890.

Copyright© 2023 Meggitt SA. All rights reserved. The information contained in this document is subject to change without prior notice.

Sales offices

Meggitt has offices in more than 30 countries. For a complete list, please visit our website.

Local representative

Head office



Meggitt SA
Route de Moncor 4
Case postale
1701 Fribourg
Switzerland

Tel: +41 26 407 11 11

Fax: +41 26 407 13 01

energy@ch.meggitt.com

www.meggittsensing.com/energy

www.meggitt.com