

RVP-200

Electrically Actuated Rotary Control Valve

Description

The RVP-200 is an Electrically Actuated Rotary Control Valve designed for a wide variety of applications and service conditions. The actuator design incorporates a brushless DC motor, a digital driver, a gearbox, and a torsional failsafe spring for precise position control and long operational life. The valve design is a hybrid butterfly and segmented ball valve providing tight shutoff, high flow capacity, high ΔP capability, and elevated pressure and temperature ranges.

Optional features that can be configured at time of order are:

- Valve body sizes from 76 mm to 203 mm (3 inches to 8 inches)
- Flanged process connections—ANSI 300 lb and 600 lb class
- Carbon or stainless steel body construction
- Fail closed or fail open
- User-specified stroke time
- Low duty on/off operation or (4 to 20) mA positioning
- Multiple discrete and analog inputs and outputs for position control, valve travel indication, limit switch, valve trip command, alarm indication



- Precise position control
- Eliminates pneumatic systems prone to moisture ingress, corrosion, and contamination
- (4 to 20) mA modulating available
- Positive spring failsafe
- International hazardous location approvals
- Eliminates pneumatic actuator bleed

Features and Benefits

The RVP-200 Electrically Actuated Rotary Control Valve is designed to serve as an alternative to pneumatically actuated control valves. The user benefits of the RVP-200 are:

1. **Reduced Total Installed Cost**—The RVP-200 requires only power and set point signal for operation. It eliminates the complexities and cost of a pneumatic system.
2. **Increased Reliability**—Electric actuation eliminates the need for clean, dry compressed air. This reduces component complexity and eliminates the traditional moisture, corrosion, and contamination that plague traditional pneumatic systems.
3. **Reduced Waste**—The RVP-200 model-based control system and stiff actuation system ensures precise control without over- or undershoot or oscillation inherent in pneumatic control systems. Tighter process control eliminates waste and improves plant profitability.
4. **Eliminates Emissions**—Traditional pneumatic actuators vent the actuation media to the environment. If the actuation media is flammable or damaging to the environment, this can present environmental compliance or personnel safety issues.

Installation

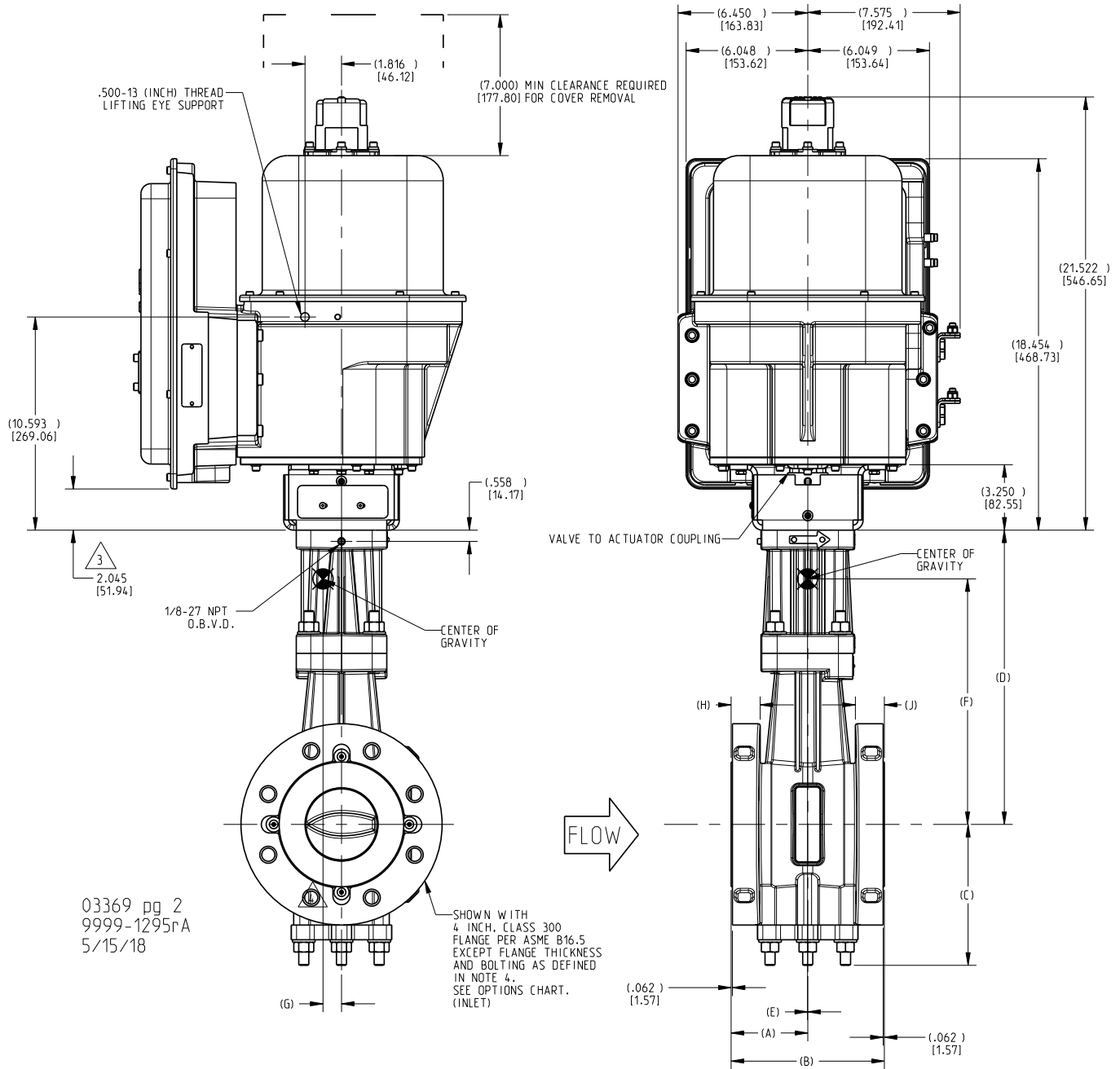

RVP-200 Outline Drawing
(inches) [mm]

OPTIONS CHART

Size	Class	Weight	Dim 'A'	Dim 'B'	Dim 'C'	Dim 'D'
3-inch	300	76 kg / 168 lb	(3.250) [82.55]	(6.500) [165.10]	(6.046) [153.57]	(14.070) [357.40]
4-inch	300	90 kg / 198 lb	(3.810) [96.77]	(7.620) [193.55]	(6.620) [168.15]	(14.625) [371.50]
6-inch	300	122 kg / 269 lb	(4.300) [109.22]	(9.000) [228.60]	(7.847) [199.31]	(15.845) [402.50]
8 inch	300	165 kg / 363 lb	(4.781) [121.44]	(9.562) [242.87]	(9.077) [230.56]	(17.444) [443.08]

Specifications

Actuator Features	Specification
CE Marking	EMC Directive: 2014/30/EU Pressure Equipment Directive: 2014/68/EU (Category II and III) ATEX Directive: 2014/34/EU (Zone 2, Category 3, Group II G, Ex nA nC IIC T4X Gc IP56) Machinery Directive: Compliant as partly completed machinery per 2006/42/EC
Other Hazardous Location Certification	IECEX: Models available marked per IECEX Certificate IECEX CSA 15.0022X as Ex nA nC IIC T4 Gc IP56 CSA: Actuator is Certified for Class I, Div. 2, Groups A,B,C,D, T4 at 82°C Amb., for use in Canada and the United States
Environmental Shock/Vibration	Vibration—WGC RV5 (10 Hz to 500 Hz, 1.04 Grms, 1.5 hours per axis) Shock—MS1, except 5 G's (11 ms sawtooth)
Action	Forward or reverse
Failure Mode	Mechanical spring return to open or closed
Ambient Temperature	(-29 to +82) °C / (-20 to +180) °F
Open/Close Time	Factory-settable for open/close between 3.8 seconds and 70 seconds. Optional, User-settable for open/close between 3.8 seconds and 70 seconds. ±1 second repeatable stroke times provided by high-performance electric actuator
Actuator Configuration and Diagnostics	User can access valve/actuator settings through optional PC-based Service Tool
Closed-loop Control	Embedded actuator software that continuously controls driver power and adapts to maintain system performance over time even during system and environmental upsets.
Diagnostics	Actuator electronics continuously monitor key system parameters optionally generate an alarm when potential problems are detected.
Installation	125 V (dc) electrical power [(90 to 150) V (dc)] 220 V (dc) electrical power [(198 to 264) V (dc)] 120 V (ac) electrical power 50/60 Hz [(85 to 132) V (ac)] (24 to 125) V (dc) discrete inputs
Input Signals	Up to 3 Discrete Inputs (DI). User-configurable software-based switches for valve open/close or run/shutdown. Open/closed input can be configured for two-wire or four-wire control. In two-wire mode (1 DI), the input will either open or close the valve by opening or closing the single two-wire circuits. In this mode, the actuator cannot determine the difference between a command and a short circuit. In the four-wire mode (2 DI's), one DI will be assigned to open, and one DI will be assigned to close. The DI's can be powered internally (from the actuator) or externally (from an external power supply). The actuator will provide only 24 V (dc) to the DI's. If the circuits are wired for external power, they are rated for (24 to 125) V (dc). Analog Input (AI). A (4 to 20) mA AI that is user-assigned for set point from the control system.
Output Signals	Up to 4 Discrete Outputs (DO's). User configurable software based switches to indicate valve position between 0 % and 100 % open or various faults/status, such as over-temp condition, over-torque, or actuator in manual mode. The DO's can be powered internally (from the actuator) or externally (from an external power supply). The actuator will provide 24 V (dc) to power the DO's. If DO's are internally powered, the total power is limited to 5 W. Assuming equal loads, this means 200 mA for 1 channel, 100 mA each for 2 channels, 50 mA each for 4 channels. If the DO circuits are externally powered they will be rated for 24 or 125 V (dc) @ 0.5 A. Up to 3 Analog Outputs (AO's). (4 to 20) mA AO's that are assigned for position indication.
Visual Indicator	Top-mounted beacon style
Switches	2 External Limit Switches. These switches are independent of actuator electronics and wired separately. They are mechanical switches that are located in an external switch housing with its own conduit entries and wiring separate from the actuator electronics. The switches can be user-adjusted to switch at any position from 0 % to 100 % open. They are rated for 125 V (dc) @ 0.5 A resistive. These switches are used if the user needs position indication in the event of an actuator power loss or other actuator failure.

Valve Features	Specification	
Process Fluid	Natural Gas, Distillate (Liquids), Water, Air, Hydrogen, Syngas, Steam and other common industrial fluids	
Valve Type	Hybrid Butterfly—Segmented ball style with disk-reinforcing carrier and upstream flow tube and valve seat	
Nominal Valve Body Sizes	ANSI—(76, 102, 152, & 203) mm / (3, 4, 6, & 8) inches	
Valve Body Material	ASTM A216 Grade WCC and ASTM A351 CF8M	
Trim Materials	Stainless steel trim components designed to meet NACE MR 0103-2003	
Process Connections	ANSI Class Raised Face—Class 300# & 600#	
Face to Face Dimensions	Per ISA 75.08	
Pressure Rating	Per ANSI B16.34 and material type up to 5171 kPa (750 psi)	
Process Fluid Temperature	(-29 to +482) °C / (-20 to +900) °F	
Maximum Differential Pressure at Shutoff	3448 kPa (500 psid)	
Valve Capacity (CV at maximum opening)	3-inch—173 6-inch—797	4-inch—375 8-inch—1708
Seat Leakage Class	FCI 70-2 Class IV – Metal Seat	
Valve Packing Leak-off Port	¼-inch (6.4 mm) NPT available	

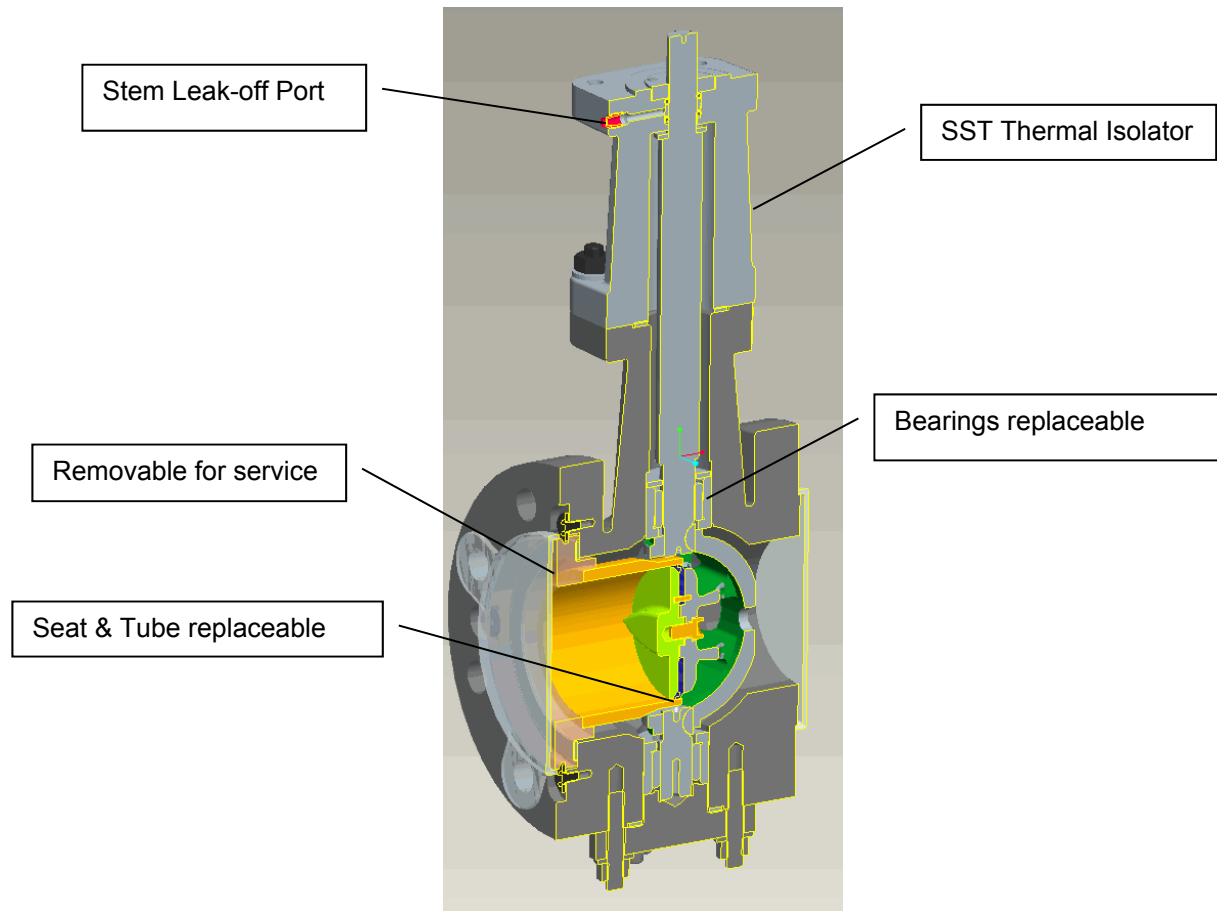

RVP-200 Cutaway Drawing



PO Box 1519, Fort Collins CO, USA 80522-1519
 1041 Woodward Way, Fort Collins CO 80524
 Tel.: +1 (970) 482-5811
www.woodward.com

Distributors & Service

Woodward has an international network of distributors and service facilities. For your nearest representative, call the Fort Collins plant or see the Worldwide Directory on our website.

This document is distributed for informational purposes only. It is not to be construed as creating or becoming part of any Woodward contractual or warranty obligation unless expressly stated in a written sales contract.

Copyright © Woodward 2011–2018, All Rights Reserved

For more information contact: