

# Liquid Shutoff Valve 25

## Applications

The liquid shutoff valve is a three-way valve designed to rapidly shut off all liquid fuel flow and prevent leakage to the turbine. In the de-energized state, the valve diverts inlet flow to bypass ports, preventing pressure damage to positive displacement fluid systems.

Normal installation of the 45 lb (20 kg) valve is in the fuel line between the fuel regulating valve and the turbine.

The valve diverts flows from the discharge to bypass ports any time the operating electrical signal is lost. The valve is available in two voltage configurations.

The valve is designed for a normal operating supply pressure of up to 1200 psig (8274 kPa) and has a rated flow of 30 000 lb/h (13 608 kg/h) based on US MIL-C-7024 calibrating fluid at 70 °F (21 °C).

## Description

The Woodward liquid shutoff valve is a two-stage valve. It uses supply pressure to provide a complete shutoff of fuel flow in 0.09 seconds or less after termination of a solenoid current. Valve closure is due to spring compression assisted by supply pressure.

An inlet screen in the valve prevents contaminants in excess of 40 µm, nominal, from damaging the pilot valve section.

The valve housing is constructed of anodized aluminum. Hardened stainless steel is used for all internal parts. The valve is designed for proof pressures of 1800 psig (12 411 kPa) and burst pressures of 6000 psig (41 370 kPa).

An optional closed valve position switch is available.

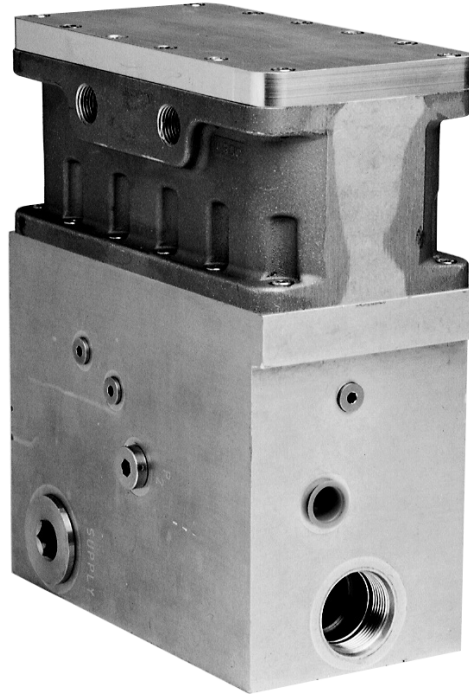

- 30 000 lb/h (13 608 kg/h) rated flow
- Closes in 0.100 seconds
- 1200 psig (8274 kPa) maximum operating pressure
- Models are available with certification for North American Hazardous Locations
- Models are available compliant with the applicable CE Directives: ATEX, PED, and Machinery

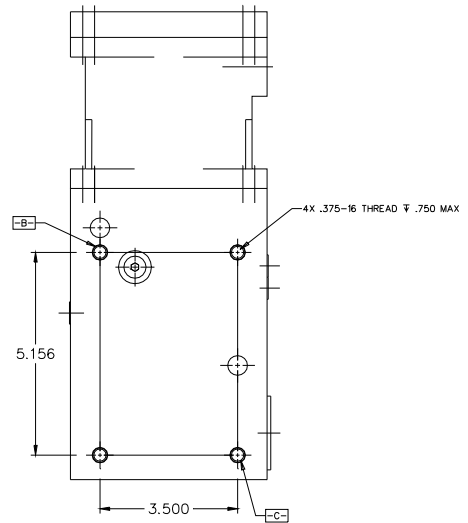
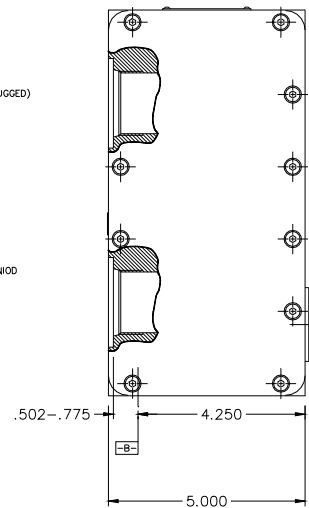
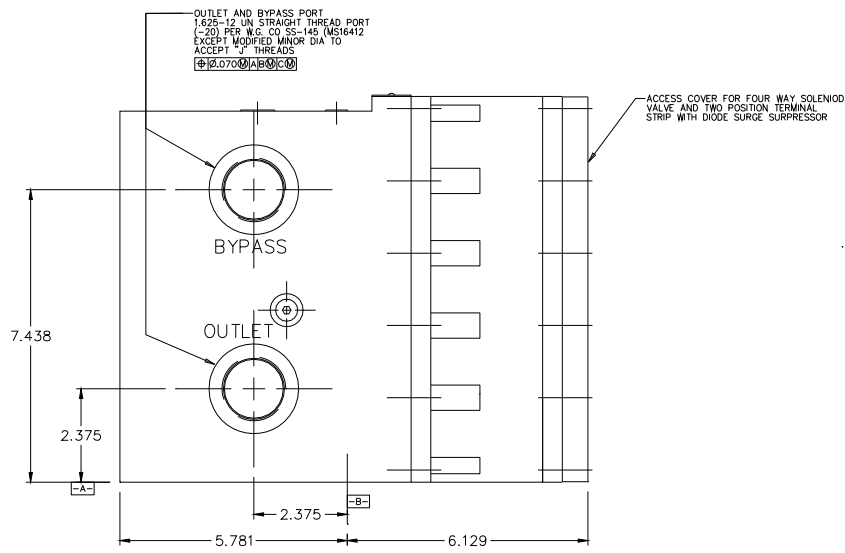
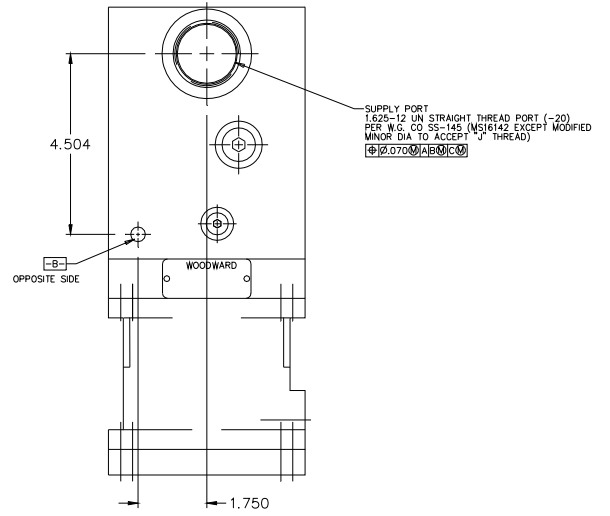
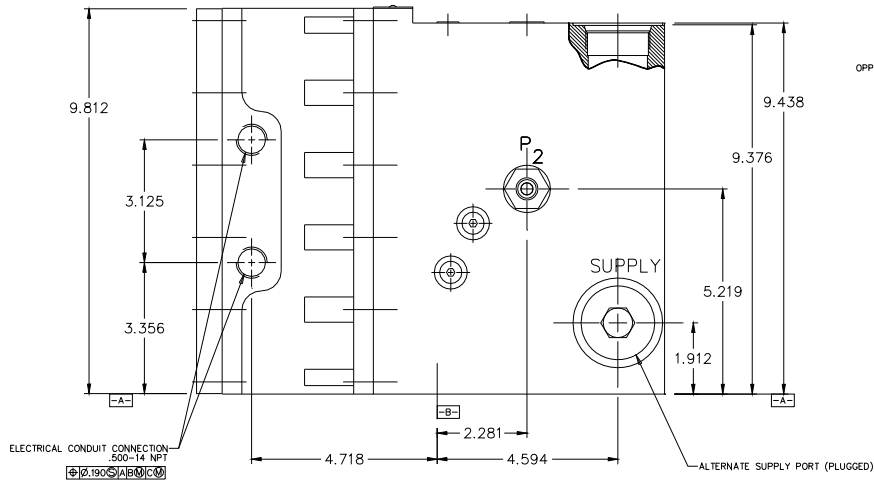

400-272A  
05-6-14

**Outline Drawing of Liquid Fuel Shutoff Valve without Proximity Switch**  
(Do not use for construction)

## Specifications

### ELECTRICAL REQUIREMENTS

<b>Voltage Available</b>	Nominal 24 Vdc, 125 Vdc
<b>Power Consumption</b>	20 W nominal
<b>Resistance to Ground</b>	10 MΩ minimum at 500 Vdc
<b>Dielectric Strength</b>	Leakage current less than 0.5 mA at 1000 Vac plus twice the rated solenoid voltage for one minute

### GENERAL

<b>Fuel Type</b>	The valve is compatible with most types of diesels, kerosenes, gasolines, heavy and light distillates including naphtha, gas turbine fuels and fuel oils, and other liquid fuels such as biodiesel that are compatible with fluorocarbon (FKM) type elastomers and conform to international standards for utility, marine, and aviation gas turbine service. Ultra low sulfur diesels are also acceptable with proper lubricity additives. Other fuels such as ethanol or methanol may be acceptable with internal seal compound substitutions. Contact Woodward for these and other special fuel applications.
<b>Fuel Viscosity</b>	Fuel viscosity must be between 0.5 and 12.0 centistokes.
<b>Fuel Cleanliness</b>	Liquid fuel must be filtered to limit particulate size to 20 μm or smaller. Water and sediment must be limited to 0.1% by volume. Total particulate concentration must be limited to 2.64 mg per liter of fuel.
<b>Fuel Temperature</b>	0 to +250 °F (–18 to +120 °C)
<b>Rated Flow</b>	30 000 lb/h (13 608 kg/h) based on US MIL-C-7024 calibrating fluid at 70 °F (21 °C)
<b>Cycle Life</b>	10 000 cycles
<b>Weight</b>	45 lb (20 kg)
<b>Construction</b>	Anodized aluminum housing. Hardened stainless steel internal components
<b>Fittings</b>	Fuel inlet, fuel outlet, and bypass ports machined to accept –20 (SAE 070120) straight thread fittings
<b>Electrical</b>	0.500-14 NPTF conduit connector or M20-1.5 cable entries

### OPERATING SPECIFICATIONS

<b>Opening Time</b>	Maximum of 0.400 seconds after admission of fuel and solenoid current
<b>Closing Time</b>	Within 0.100 seconds after the solenoid is de-energized with 100–1200 psig (690–8274 kPa) fuel applied to the inlet
<b>Pressure Drop</b>	53 psid (365 kPa) inlet to discharge at 30 000 lb/h (13 608 kg/h) 139 psid (958 kPa) inlet to bypass at 30 000 lb/h (13 608 kg/h)
<b>Internal Leakage Shutoff</b>	From inlet to discharge: None From inlet to bypass: 500 ccm maximum at 800 psid (5516 kPa) 900 psig (6206 kPa)
<b>Reverse Pressure Condition</b>	
<b>Fluid Supply Pressure:</b>	
<b>Normal</b>	1200 psig (8274 kPa) range
<b>Proof</b>	1800 psig (12 411 kPa)
<b>Burst</b>	6000 psi (41 370 kPa)
<b>Maximum Bypass Pressure</b>	250 psig (1724 kPa)
<b>Cracking Pressure</b>	100 psi (690 kPa) above reference pressure (bypass)

### REGULATORY COMPLIANCE

#### European Compliance for CE Marking:

These listings are limited only to those units bearing the CE Marking.

<b>Pressure Equipment Directive:</b>	Directive 97/23/EC (until July 18th, 2016) and Directive 2014/68/EU (from July 19, 2016) on the harmonisation of the laws of the Member States relating to the making available on the market of pressure equipment. PED Category II PED Module H – Full Quality Assurance, CE-0041-PED-H-WDI 001-16-USA, Bureau Veritas UK Ltd (0041)
--------------------------------------	---

<b>ATEX–Potentially Explosive Atmospheres Directive:</b>	Directive 2014/34/EU (from April 20th, 2016) on the harmonisation of the laws of the Member States relating to equipment and protective systems intended for use in potentially explosive atmospheres Sira 11ATEX1233X Zone 1, Category 2, Group II G, Ex d IIB T4 Gb  Self-declared (9908-354 only) Zone 2, Category 3, Group II G, Ex nC IIC T3 X
--	--

#### Other European Compliance

Compliance with the following European Directives or standards does not qualify this product for application of the CE Marking:

<b>Machinery Directive:</b>	Compliant as partly completed machinery with Directive 2006/42/EC of the European Parliament and the Council of 17 May 2006 on machinery.
-----------------------------	---

#### Other International Compliance

<b>IECEX:</b>	IECEX CSA 11.0013X Ex d IIB T4
---------------	--------------------------------

**North American Compliance:**

These listings are limited only to those units bearing the CSA agency identification.

**CSA:** CSA Certified for Class I, Division 1, Groups C & D, and Class I, Division 2, Groups B, C, & D, T4 at 121 °C Ambient for use in Canada and the United States

**Proximity Switch Version:** CSA Certified for Class I, Division 1, Group D and Class I, Division 2, Groups B, C, & D, T4 at 121 °C Ambient for use in Canada and the United States.

**SIL: Safety Integrity Level:**  
Systematic Capability: SC 2 (SIL 2 Capable)  
IEC 61508 Failure Rates in FIT\*

Device	$\lambda_{SD}$	$\lambda_{SU}^2$	$\lambda_{DD}$	$\lambda_{DU}$
Full Stroke	0	705	0	765

\*FIT = 1 failure / 10<sup>9</sup> hour

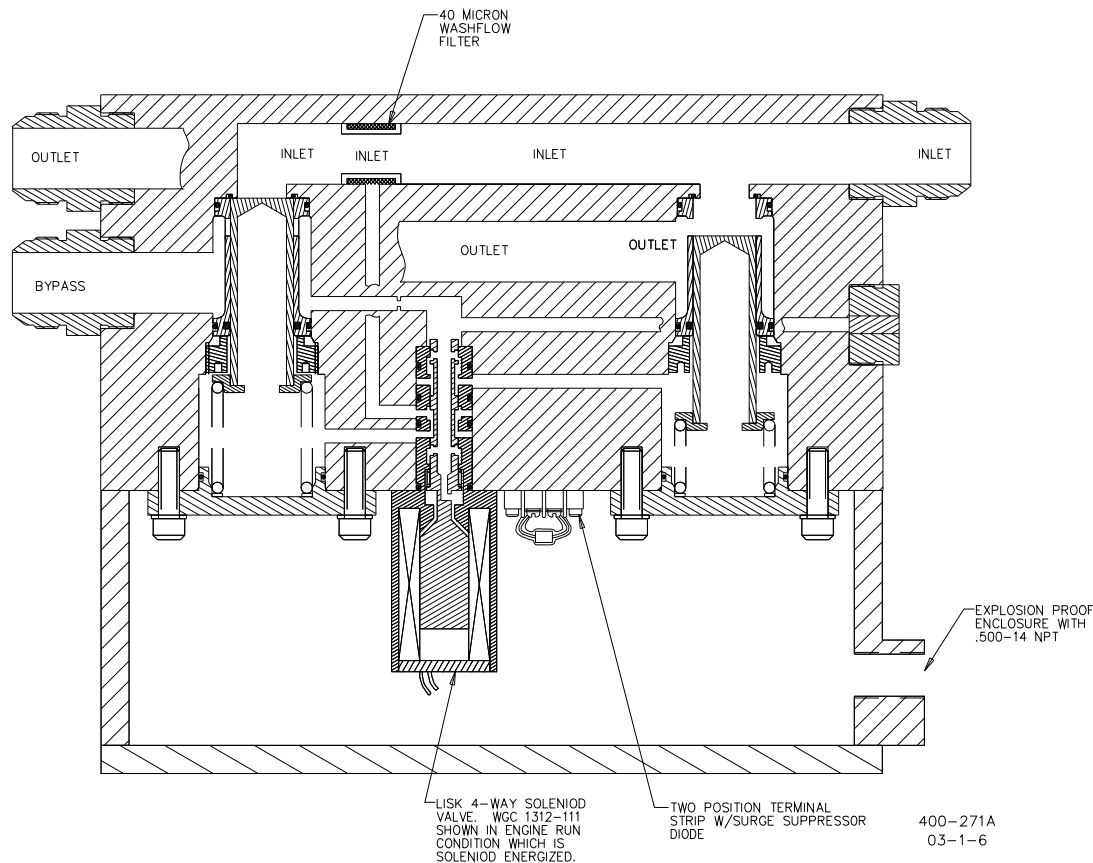

### Schematic Diagram of Liquid Shutoff Valve in the Energized Mode without Proximity Switch

See the Technical Manual 40148 for more information on the proximity switch version.



PO Box 1519, Fort Collins CO, USA 80522-1519  
1000 East Drake Road, Fort Collins CO 80525  
Tel.: +1 (970) 482-5811  
[www.woodward.com](http://www.woodward.com)

#### Distributors & Service

Woodward has an international network of distributors and service facilities. For your nearest representative, call the Fort Collins plant or see the Worldwide Directory on our website.

This document is distributed for informational purposes only. It is not to be construed as creating or becoming part of any Woodward contractual or warranty obligation unless expressly stated in a written sales contract.

Copyright © Woodward 1989-2016, All Rights Reserved

For more information contact:

