

ESSE Series Electronic Speed Switches

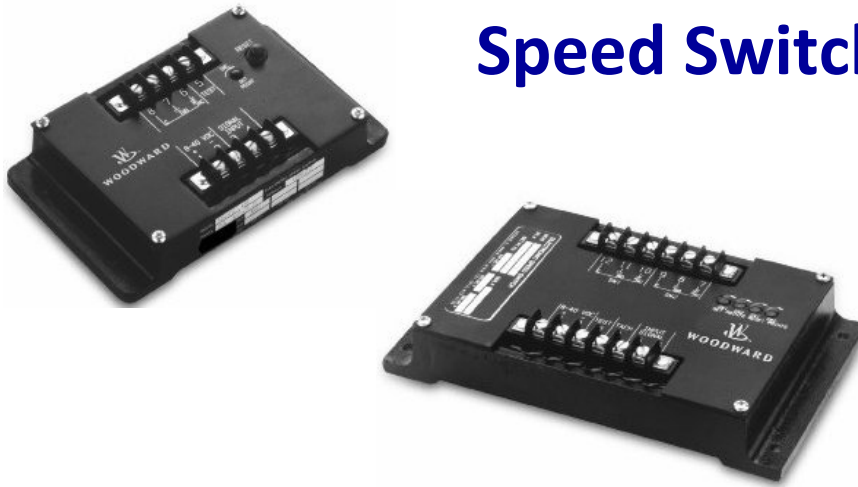

Description

Woodward's ESSE Series are single channel (ESSE-1) or two channel (ESSE-2) electronic speed switches with exceptional power transient protection. The units are potted for protection against harsh environments and have proven to be reliable and rugged as well as flexible and cost effective.

In generator set applications, the ESSE Series can be used for crank (starter motor) disconnect or overspeed protection, or for underspeed and overspeed warnings. In fact, most speed-related switching functions on diesel and gas engines and other rotating machinery can be accommodated by ESSE speed switches.

The speed switches can receive signal input from a magnetic pickup, alternator, ignition coil, or Woodward's Mini-Gen signal generator.

Both ESSE-1 and ESSE-2 offer four reset options for resetting the speed switch. *Electrical Latch Option* -The switch (after the set point has been reached) will close and remain closed even if the input signal frequency has been lowered to 0 Hertz. The only way to reset the unit is to remove power. *Manual Reset Option* – By depressing the ESSE's reset button, the unit will be reset. *Automatic Reset Option* - The switch will automatically reset if the frequency of the input signal is lowered to $85 \pm 5\%$. The automatic and latch options are field selectable. *Adjustable (automatic) Reset Option* - The switch will automatically reset at the frequency determined by the setting of the supplied reset pot. By adjusting the pot, the reset can be selected anywhere between 25% and 95%.

In addition to their standard features, ESSE speed switches provide options on the input voltage range of operation, setpoint range, reset of tripped setpoint switches, reverse relay logic control, and ignition signal input.

For additional information visit www.woodward.com/searchpublications to download or view Technical Manual 36555 (ESSE-1) or Technical Manual 36564 (ESSE-2),

- Standard or reverse relay operation
- Field adjustable set and reset switch points
- High noise immunity
- Latch, automatic, manual or adjustable resets
- Reverse polarity protection
- Test circuit (trips at $67\% \pm 10\%$ of setpoint)
- Field selectable setpoint range
- Potted for in-field reliability, exposed applications, and hostile environments

Specifications

SPECIFICATION	ESSE-1	ESSE-2	
Operating Temperature	-40°F to +185°F (-40°C to +85°C)		
Input Voltage Range	8-40 Vdc	8-40 Vdc	40-80 Vdc
Maximum Operating Current:			
@ 12 V	125 mA	200 mA	—
@ 24 V	140 mA	220 mA	—
@ 40 V	165 mA	250 mA	90 mA
@ 64 V	—	—	100 mA
@ 80 V	—	—	115 mA
Maximum Standby Current:			
@ 12 V	30 mA	30 mA	—
@ 24 V	45 mA	45 mA	—
@ 40 V	70 mA	70 mA	50 mA
@ 64 V	—	—	60 mA
@ 80 V	—	—	75 mA
Relay Contact Ratings:			
28 Vdc Resistive Load	0.1-10 A	0.1-10 A	—
28 Vdc Inductive Load	0.1-8 A	0.1-8 A	—
75 Vdc Resistive Load	—	—	0.1-4 A
75 Vdc Inductive Load	—	—	0.1-3 A
Power Supply Transient Protection	900 Vdc for 100 ms exponential decay 140 Vdc for 1 ms 110 Vdc for 0.45 s		
Reverse Polarity Protection	1000 Vdc		
Signal Input:			
Minimum	1.2 V _{rms}		
Maximum	130 V _{rms}		
Signal Input Impedance	33K Ohms (nominal)		
Overspeed Response Time	75 ms typical		
Setpoint Reset	Automatic (80%- 90% of setpoint) / Automatic Adjustable (25%-95% of setpoint) / Electrical Latch/ Manual Reset		
Setpoint Stability @ 9 Vdc to 40 Vdc and 14°F to +185°F (-10°C to +85°C)	Less than 1% or 8 Hz, whichever is greater. Unit performs to -40° F (-40° C)		
Vibration	4.2 G's from 20 to 500 Hz		
Shock	4' drop test		
Case	Cast aluminum 1/4" wall thickness Nickel plated terminals. Humidity and salt spray resistant. Potted electronics for environmental protection		
Weight	1.5 lbs (0.68 kg)	2 lbs (0.91 kg)	

Dimensions

ESSE-1

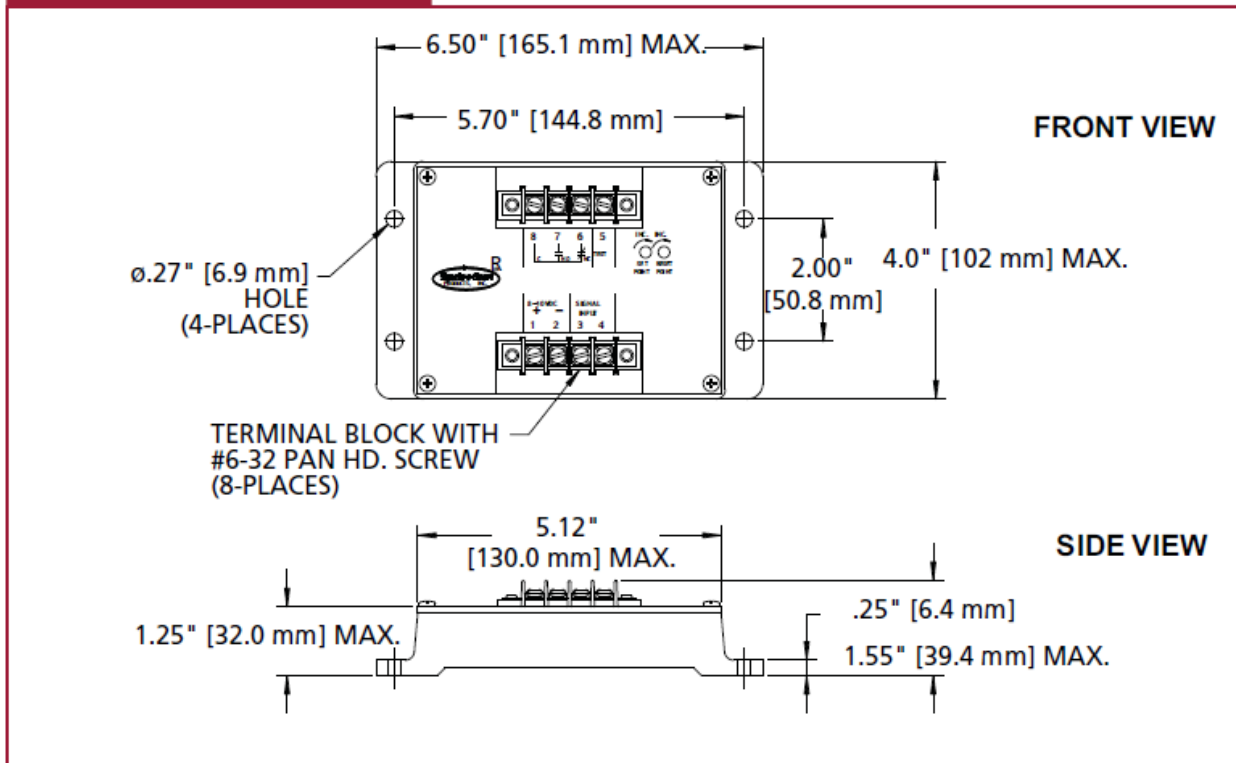

Figure 1. ESSE-1 Dimensions

ESSE-2

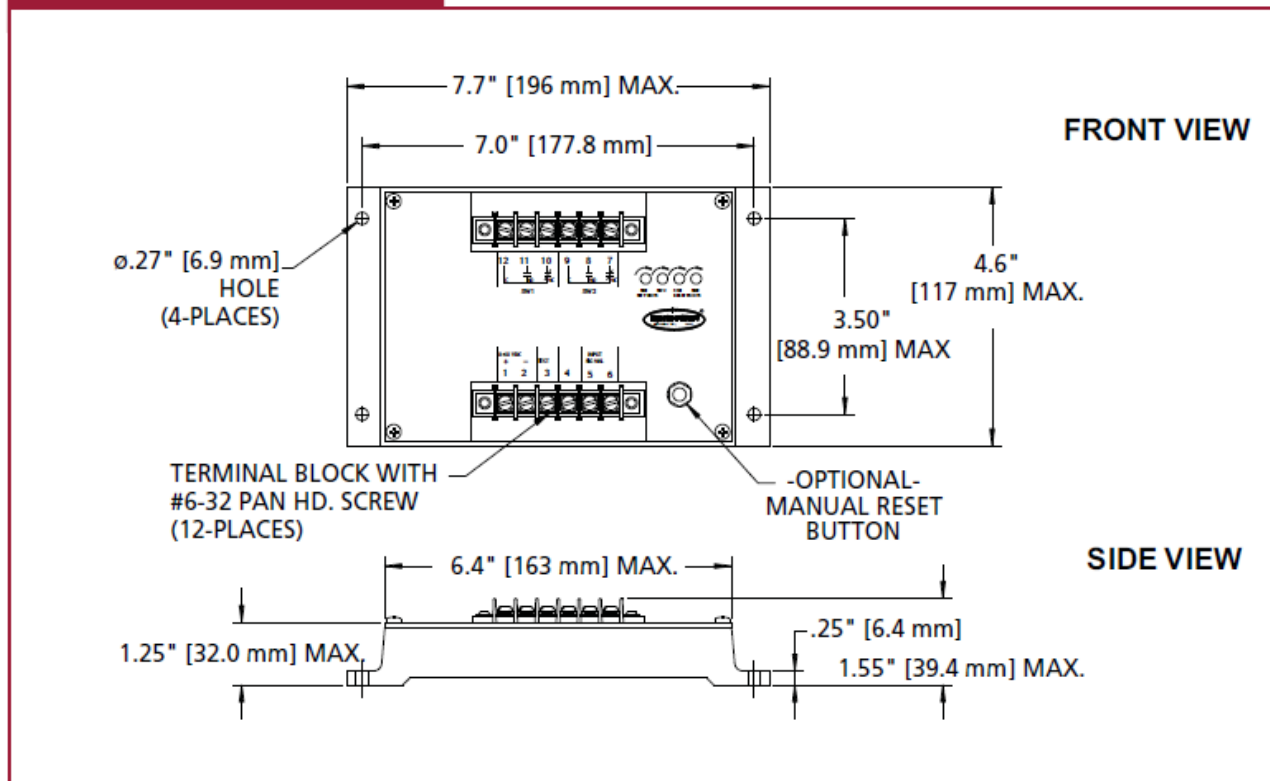

Figure 2. ESSE-2 Dimensions

How to Select a Speed Switch

When selecting the best speed switch for controlling a particular application, the key factors to consider are the number of switch points, frequency range of application, setpoints, and signal source. The frequency range of the application and setpoints are dependent upon the selection of the signal source, which in turn depends upon the operating speed and physical mounting limitations. Use the chart below to determine your setpoint frequency. Refer to Figure 3 to select the ESSE model that is best suited to your needs.

SIGNAL SOURCE	DESCRIPTION	SETPOINT FREQUENCY (HZ)
Magnetic Pickup	Commonly used for higher speed applications. The output is a function of the "gap" between the pickup and the gear tooth and peripheral velocity of the gear.	$\frac{\text{No. of Gear Teeth} \times \text{Engine RPM Setpoint}}{60}$
Mini-Gen Signal Generator	Designed to provide outstanding signal output at speeds as low as 20 RPM.	$\frac{\text{Mini-Gen RPM @ Engine RPM Setpoint}}{2}$
Alternator Output	Used in applications unable to accommodate a magnetic pickup or Mini-Gen.	$\frac{\text{Pulley Ratio} \times \text{No. of Alternate Poles} \times \text{Engine RPM Setpoint}}{120}$
Ignition Output	Commonly used as a source for gasoline and natural gas.	$\frac{\text{No. of Cylinders} \times \text{Engine RPM Setpoint}}{120}$

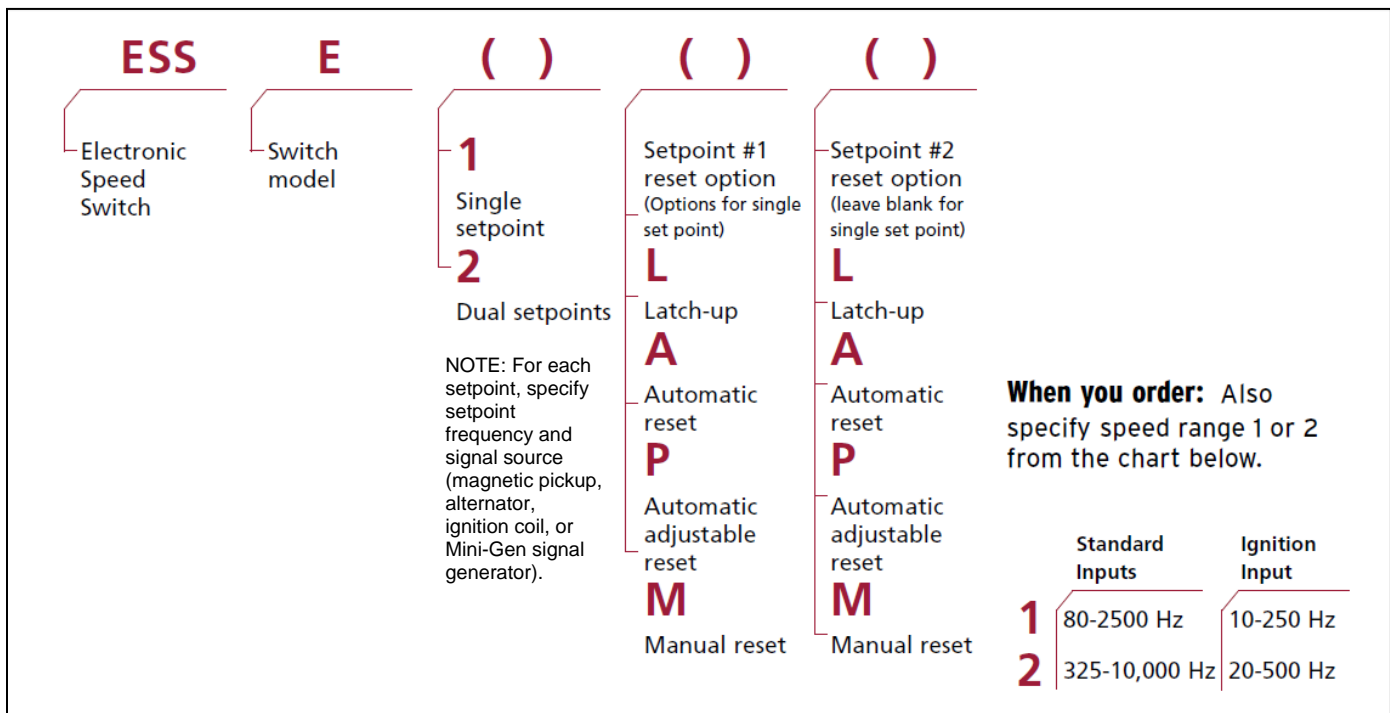

Figure 3. ESSE Series Model Descriptions



PO Box 1519, Fort Collins CO 80522-1519, USA
1000 East Drake Road, Fort Collins CO 80525, USA
Phone +1 (970) 482-5811 • Fax +1 (970) 498-3058
Email and Website—www.woodward.com

Woodward has company-owned plants, subsidiaries, and branches, as well as authorized distributors and other authorized service and sales facilities throughout the world. Complete address / phone / fax / email information for all locations is available on our website.

This document is distributed for informational purposes only. It is not to be construed as creating or becoming part of any Woodward contractual or warranty obligation unless expressly stated in a written sales contract.

Copyright © Woodward 2013, All Rights Reserved

For more information contact: