

## easYgen-1600 / easYgen-1800



### easYgen-1800 Unique Features

- ✓ Large LCD color display for enhanced user experience
- ✓ Built-in Ethernet for remote control, browser based visualization, and service tool connectivity
- ✓ SD card slot for life long data log

## Automatic Mains Failure Control

**Do you package gensets, build switchgear or integrate systems?** With several decades of experience in genset control technology Woodward's easYgen family offers a one-stop-shop standardization opportunity for all of your genset control needs. easYgen family genset controls cover full range of generator system applications ranging from simple start/stop control to complex synchronizing and power management controls.

### DESCRIPTION

Woodward easYgen-1000 series is designed for single generator set used in stand-by or prime power applications. The controllers include purpose built algorithms and logic to start, stop, control, and protect the genset, open/close circuit breakers and – if applicable – mains supply monitoring with automatic changeover. Equipped with state of the art communication interfaces, Woodward's easYgen-1000 Series AMF genset controllers provide exceptional versatility and value for the OEM genset packagers.

The easYgen-1000 Series is available in two variants:

- **easYgen-1800** advanced AMF controller comes with a large liquid crystal display (LCD), I/O expansion possibility, Ethernet and SD card connectivity
- **easYgen-1600** compact AMF controls offer a state of the art LCD, adequate on-board I/Os and common industrial connectivity

Easy-to-use software **ToolKit-SC** simplifies configuring the controllers for standard system application as well as making it easy to customize it for individual solutions. Additionally, the module's integral front panel allows adjustment of several parameters.

### FEATURES

- Three-phase true RMS power sensing
- Operation modes: AUTO, STOP, and MANUAL modes accessible through front panel, discrete inputs or via interfaces
- Remote control via multiple interfaces and via discrete inputs
- Direct support of several ECUs such as Bosch, Cummins, John Deere, MTU, Perkins, Scania, Volvo, Woodward
- Two 16 A relay outputs for cranking and fuel solenoid
- Event and data logging capability with real time clock
- Maintenance scheduler with multipurpose flexible timers
- Operating hours, start, maintenance counters and monitoring
- Three switchable parameter sets of AC system winding, Rated Voltage, Rated Frequency, Rated Current, Rated Power, Rated Speed
- Can be applied on pumping units as an indicating instrument (relays are inhibited)
- Fully configurable via PC using USB, RS485 or Ethernet. Front panel configurable with password protection
- Manual breaker operation with tactile buttons on front panel
- Customizable boot-up logo with adjustable screen display time
- Multilingual capability selectable on site

- Standard break-before-make application in
  - Stand-by operation
  - AMF (Automatic Mains Failure) operation
  - ATS (Automatic Transfer Switch) operation
  - Rental power operation
  - Peak shaving operation
- Easy to set up and commission
- Best in class large liquid crystal display
- Comprehensive engine, generator and utility protection
- Engine ECU interface to electronic engines
- Programmable I/Os
- Six communication ports: Ethernet TCP/IP, CAN J1939, RS-485, RS232, USB, SD card slot
- Dedicated heavy duty relays for engine and breaker interface
- Switchable parameter sets for mobile genset applications
- Event log and event triggered data log

## SPECIFICATIONS

### Power Supply

Operating Voltage (Reverse polarity protected)	8.0 V <sub>DC</sub> to 35.0 V <sub>DC</sub> , Continuous Power Supply.
Maximum supply voltage	Short Time 80 V (5-10 s); Long T. 50 V
Minimum supply voltage	6.5 V
Maximum operating current	(All relays closed, LCD bright) 380 mA (12 V); 188 mA (24 V)
Maximum standby current	(All relays closed, LCD dimmed) 90 mA (12 V); 42 mA (24 V)
Power Consumption	<4 W (standby ≤ 2 W)
Battery voltage measurement	Accuracy: 1% (12V/24V)

### Alternator Input Range

	50 Hz/60 Hz
3-Phase 4-Wire	AC15V - AC360V (ph-N)
3-Phase 3-Wire	AC30V - AC620V (ph-ph)
Single-Phase 2-Wire	AC15V - AC360V (ph-N)
2-Phase 3-Wire	AC15V - AC360V (ph-N)

### AC-Measurement

	Phase-phase: 100 .. 624 V : 1%;
Voltage Accuracy (400/480 V % rated)	50 .. 100 V : 1.5 % Phase-neutral: 100 .. 360 V : 1% 50 .. 100 V : 1.5 %

Minimum frequency	Generator: 10 Hz; Mains: 27 Hz
Maximum frequency	Generator: 99.5 Hz; Mains: 99.5 Hz
Frequency resolution	0.1 Hz (10 .. 99 Hz)
Frequency accuracy	±0.1 Hz
Nominal CT secondary rating	5 A
Overload Measurement	Max.: 10 A
Current Accuracy	1 %

### Housing

Case Dimension	easYgen-1800: 237 x 172 x 45 mm <sup>3</sup> easYgen-1600: 209 X 166 x 45 mm <sup>3</sup>
Panel Cutout	easYgen-1800: 214 x 160 mm <sup>2</sup> easYgen-1600: 186 x 141 mm <sup>2</sup>
Working Conditions	Temperature: (-25 to +70) °C; Humidity: (20 to 93) %RH
Storage Condition	Temperature: (-25 to +70) °C
Protection Level	IP65 in the front, mounted with kit IP20 on rear side

### Insulating Intensity:

Apply 2.2 kV<sub>AC</sub> voltage between high voltage terminal and low voltage terminal. The leakage current is not more than 3 mA within 1 min.

Net Weight	0.85 kg	
<b>Speed Sensor</b>	Voltage	1.0 V to 24.0 V (RMS)
	Frequency	10,000 Hz (max.)
Excitation current D+	110 mA (12 V); 230 mA (24 V)	
Start Relay Output	16 A DC28V supply output	
Fuel Relay Output	16 A DC28V supply output	
Auxiliary Relay Output (1 .. 3)	7 A DC28V supply output	
Auxiliary Relay Output (4 .. 6)	7 A AC250V voltage free output	

### Discrete Inputs

Low level threshold	Approx. 1.3 V
Maximum input voltage	60 V
Minimum input voltage	0 V
High level threshold	1.7 V

## APPLICATION

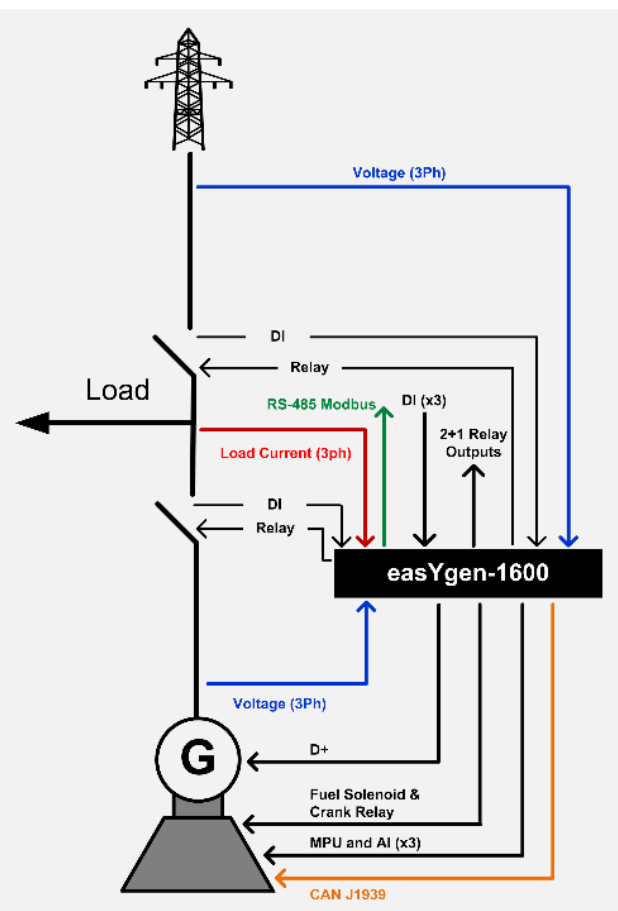
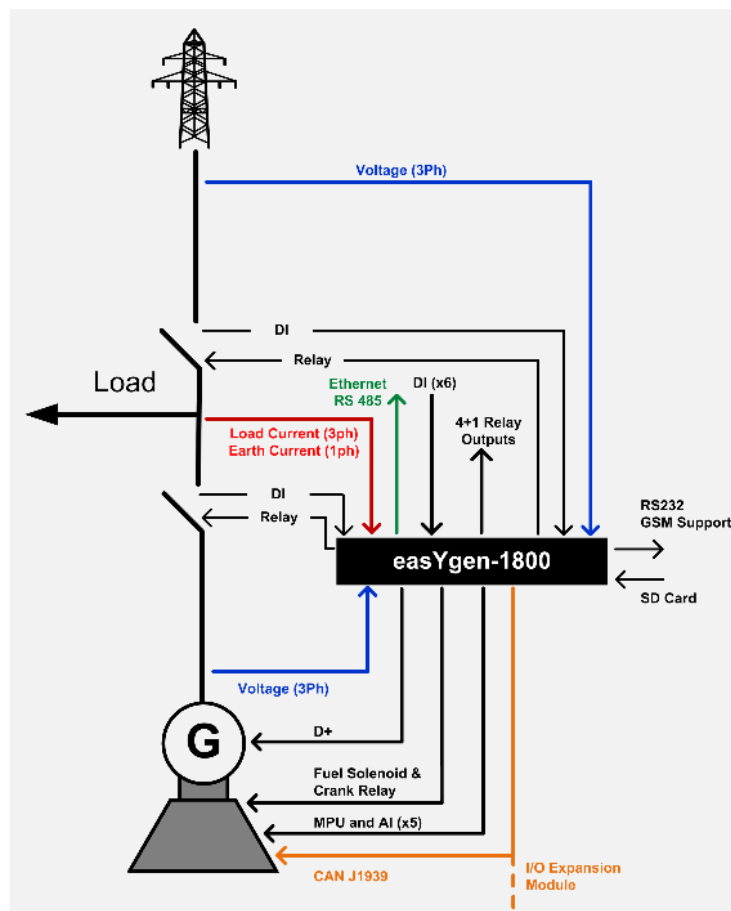

# DIMENSIONS

easYgen-1600

CUTOUT

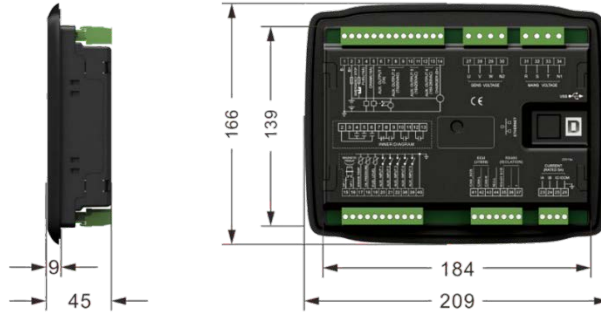
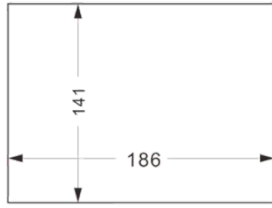

easYgen-1800

CUTOUT

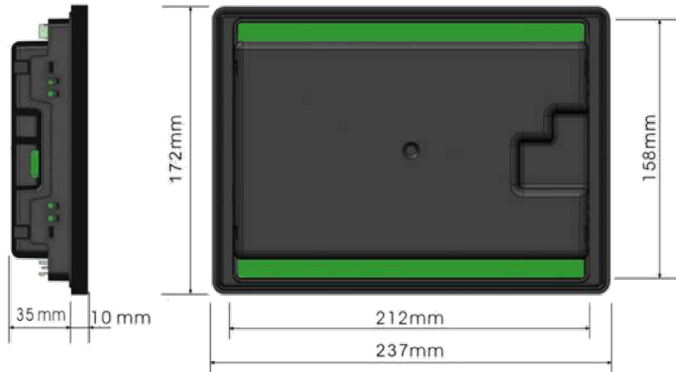

# TERMINAL DIAGRAM

easYgen-1600

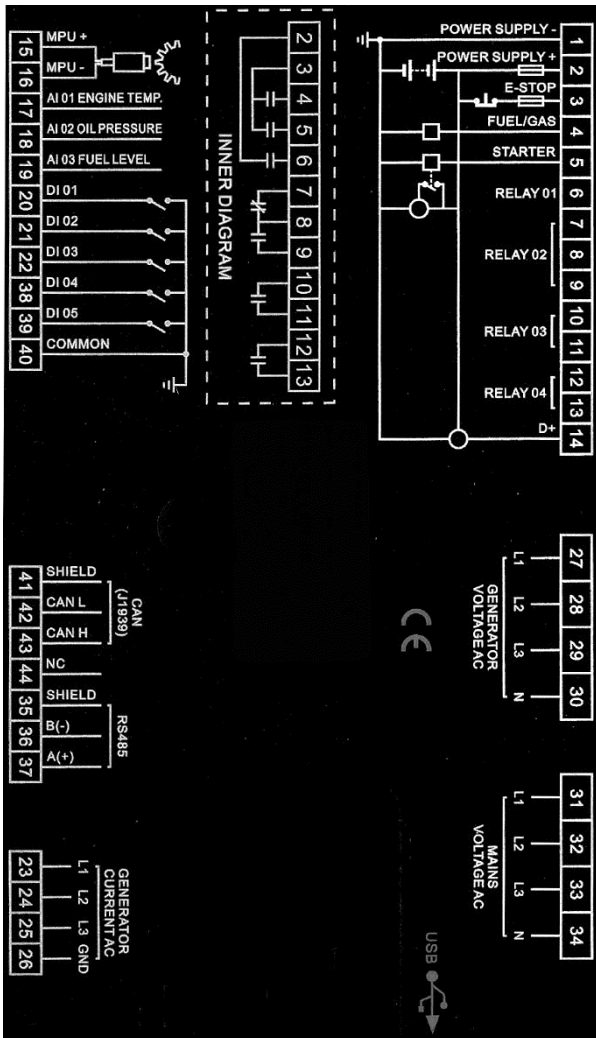

easYgen-1800

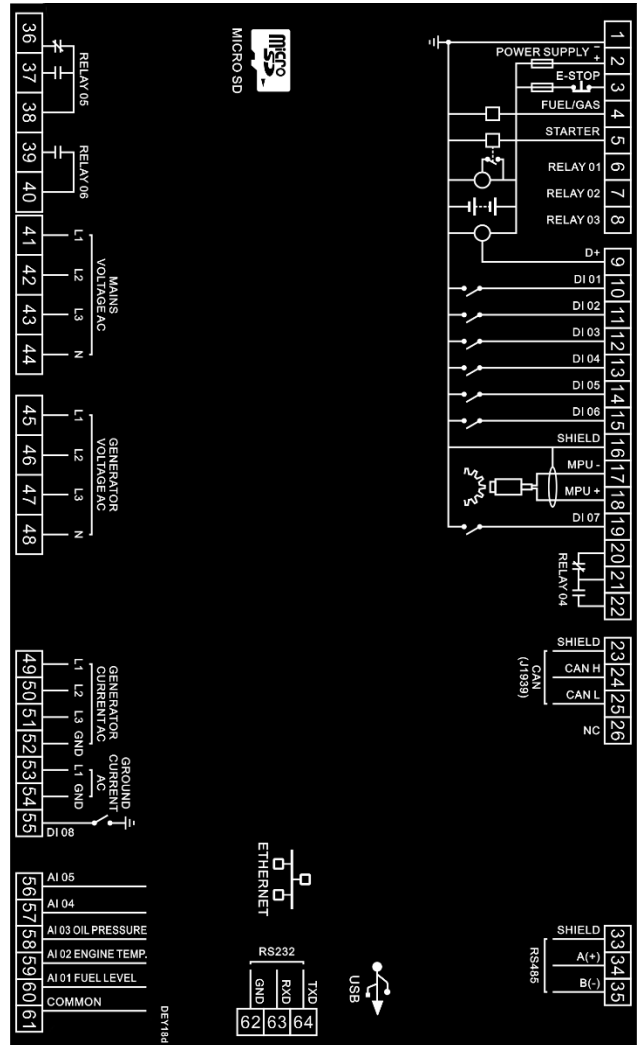

## CONTACT

## North &amp; Central America

Tel.: +1 (208) 278 3370

Tel.: +1 (970) 962-7272

✉ [SalesPGD\\_NAandCA@woodward.com](mailto:SalesPGD_NAandCA@woodward.com)

## South America

Tel.: +55 19 3708 4760

✉ [SalesPGD\\_SA@woodward.com](mailto:SalesPGD_SA@woodward.com)

## Europe

Tel. Stuttgart: +49 711 78954 510

Tel. Kempen: +49 2152 145 331

✉ [SalesPGD\\_EMEA@woodward.com](mailto:SalesPGD_EMEA@woodward.com)

## Middle East &amp; Africa

Tel.: +971 (2) 678 4424

✉ [SalesPGD\\_EMEA@woodward.com](mailto:SalesPGD_EMEA@woodward.com)

## Russia

Tel.: +49 711 78954-515

✉ [SalesPGD\\_EMEA@woodward.com](mailto:SalesPGD_EMEA@woodward.com)

## China

Tel.: +86 512 8818 5515

✉ [SalesPGD\\_CHINA@woodward.com](mailto:SalesPGD_CHINA@woodward.com)

## India

Tel.: +91 124 4399 500

✉ [Sales\\_India@woodward.com](mailto:Sales_India@woodward.com)

## ASEAN &amp; Oceania

Tel.: +49 711 78954 510

✉ [SalesPGD\\_ASEAN@woodward.com](mailto:SalesPGD_ASEAN@woodward.com)

www.woodward.com

Subject to alterations, errors excepted.

Subject to technical modifications.

This document is distributed for informational purposes only. It is not to be construed as creating or becoming part of any Woodward Company contractual or warranty obligation unless expressly stated in a written sales contract.

We appreciate your comments about the content of our publications. Please send comments including the document number below to  
stgt-doc@woodward.com

© **Woodward**  
**All Rights Reserved**

For more information contact:

## FEATURES OVERVIEW

EASyGEN 1000	Model	easYgen-1000 Series	
		easYgen-1600	easYgen-1800
<b>Measuring</b>			
Generator voltage (3-phase/4-wire)			
Load current (3x true r.m.s.)		✓	
Mains voltage (3-phase/4-wire)			
Earth current (1x true r.m.s.)		-/-	✓
<b>Control</b>			
Mains supply monitoring and automatic changeover		✓	
GCB and MCB control			
Start/stop sequence for diesel and gas engines		Diesel	Diesel/Gas
Isolated single unit operation			
AMF (Automatic Mains Failure operation)			
Stand-by operation		✓	
Open transition (break-before-make)			
ATS (Automatic Transfer Switching)			
<b>Protection</b>			
Generator	Voltage		
	Frequency		✓
	Loss of phase		
	Phase sequence		
	Current		
	Reverse Power		✓
Mains	Overload		
	Earth fault	-/-	✓
	Voltage		
Engine	Frequency		✓
	Loss of phase		
	Phase sequence		
Battery voltage	Over speed		
	Under speed		✓
	Loss of speed		
	Crank disconnect		
<b>HMI, Counters, and Event Log</b>			
Integral display with tactile buttons		Monochrome LCD (132 x 64)	TFT LCD ( 480 x 272)
Customizable power-up text and image		✓	✓
Front panel configuration with PIN protection		✓	✓
Flush mounting		✓	✓
Operating hours/start/maintenance counters		✓	✓
Event recorder with real time clock		50	99 internal; extended data log using SD card
kWh, kvarh		✓	✓
Switchable parameter sets		-	✓
<b>I/Os and Interfaces</b>			
Discrete inputs		1x E-Stop, 5x configurable	1x E-Stop, 8x configurable
Relay outputs		1x Fuel (16 A), 1x Start (16 A), 4x configurable	1x Fuel (16 A), 1x Start (16 A), 6x configurable
Analog inputs		3x resistive	5x (VDO, RTD, mA)
Speed input (MPU)		1	1
Aux. excitation (D+)		1	1
Ethernet (TCP/IP)		Option	1
CAN (J1939)		1	1
External DI/DO via CAN bus		-/-	16 / 16
USB service port		1	1
RS485		1	1
RS232		-	1
Micro SD card slot		-	1
<b>Listings/Approvals</b>			
CE Marked			✓
UL / cUL Listing, EAC			Pending
<b>Part Numbers</b>			
Control with connectors and fastening kit		8440-3004	8440-3005
Spare connector kit		10-004-674	10-004-675

## RELATED PRODUCTS

ToolKit-SC (Product Specification # 37695)

I/O Expansion Boards:

- **WWDIN16** (Product Specification # 37693): **P/N 10-004-620**
  - **WWDOUT16** (Product Specification # 37694): **P/N 10-004-623**
- Small Engine Control Module **SECM-70** (Product Specification # 36363)